

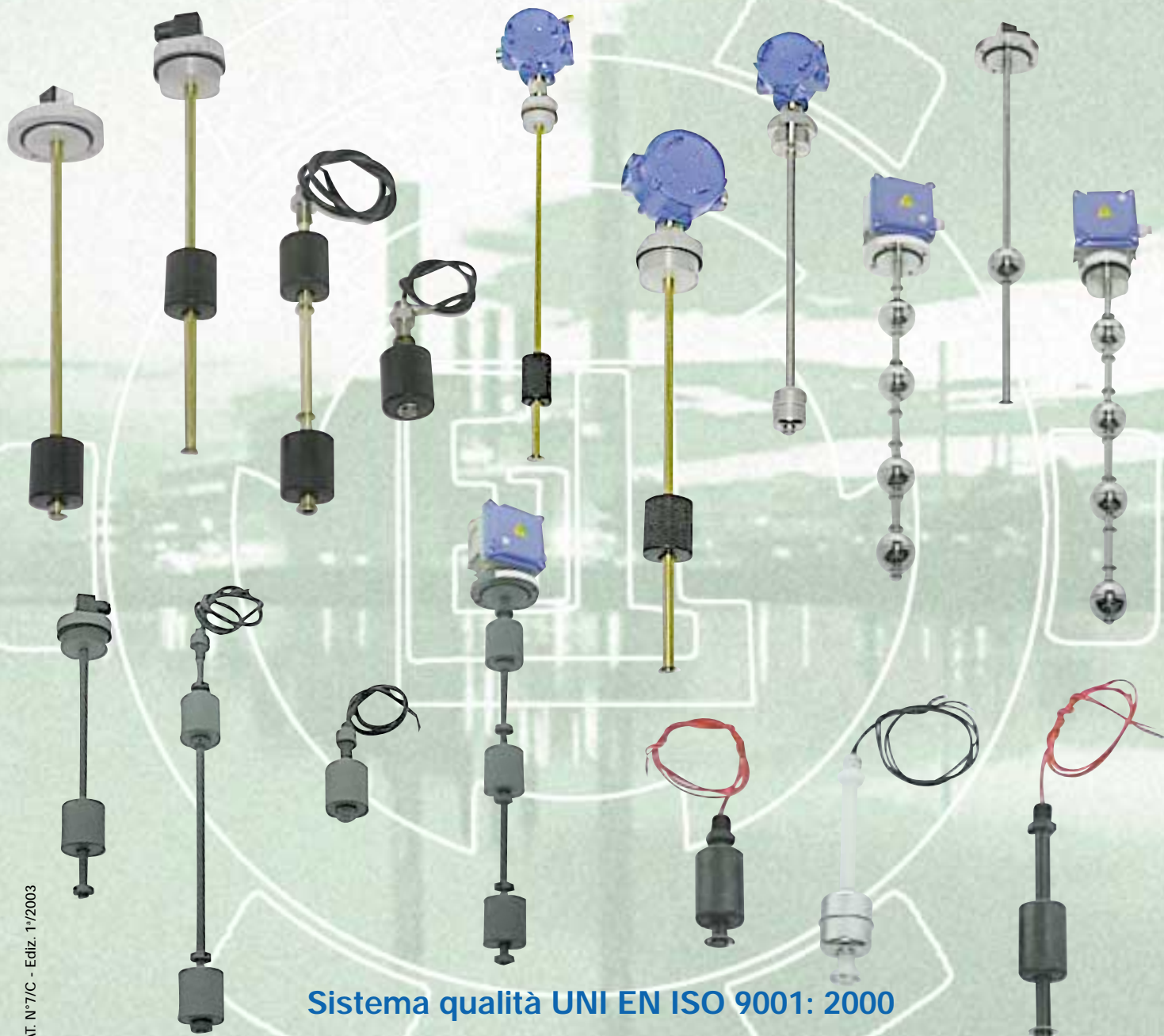

ELETTROTEC

LIVELLOSTATI ELETTROMAGNETICI

Electromagnetic level switches



PRESENTAZIONE DELLA SOCIETÀ

Company profile

"25 ANNI DI ELETTROTEC" "Elettrotec: 25 years on the market"

Elettrotec, fondata nel 1977 da Pietro Cremaschi, ha iniziato la sua attività con la progettazione e produzione di pressostati miniaturizzati regolabili, indicatori di livello elettromagnetici, flussimetri e flussostati visivi ed elettrici regolabili.

Il rapido ed incoraggiante inserimento nel mercato ha indotto la Società a muoversi verso investimenti mirati e ad aggiornare costantemente i prodotti, in linea con l'evolversi della tecnologia e sempre nella precisa visione di soddisfare le necessità dei propri clienti. Durante i suoi 25 anni di attività, caratterizzati da grandi mutamenti e crescente competitività, la Società ha saputo migliorare e ampliare la propria offerta con nuove serie di livellostati, flussostati, pressostati, vuotostati e termostati cogliendo le aspettative dei clienti e del mercato in generale sia italiano che estero.

Questo processo di evoluzione e l'attenzione dedicata ai rapidi mutamenti richiesti dal mercato sono tuttora parte integrante della politica aziendale. Infatti, oltre alle molteplici soluzioni specifiche e personalizzate sviluppatesi nel tempo, al core business consolidato dell'azienda, dal 2002 si sono aggiunte anche due nuove linee espressamente dedicate al settore dell'elettronica. Una sfida questa intrapresa per poter ampliare l'offerta Elettrotec anche a tutte quelle applicazioni che oggi richiedono un monitoraggio più preciso. Inoltre, a completamento della produzione, è d'obbligo citare anche una vasta gamma di accessori, quali cappucci di protezione e connettori, tra i quali spicca la nuova serie di connettori DIN in involucro trasparente e LED bicolore rosso/verde, ideata per essere impiegata su tutta la gamma di prodotti Elettrotec e non solo.

I grandi investimenti e l'impegno profuso hanno comunque portato a ottimi risultati, rendendo la Società una vera protagonista nel campo della strumentazione. Elettrotec vanta oggi una presenza altamente qualificata in importanti settori, quali: industria meccanica, farmaceutica, elettromedicale, cosmetica, alimentare, tessile e ospedaliera, trasporto ferroviario, macchine agricole, oleodinamica, pneumatica, automazione, impianti di lubrificazione, ascensori, sistemi antincendio, macchine movimento terra e scambiatori di calore.

La Società, certificata UNI EN ISO 9001: 2000, è caratterizzata dal lavoro di team, dove tutte le componenti aziendali – dal Marketing alla Spedizione materiali – collaborano a stretto contatto. Questo, unitamente alla consapevolezza di dover competere a livello mondiale, forma il cardine di quello che la direzione definisce un sistema organizzativo in continuo sviluppo, in perfetta sintonia con quelle che sono le esigenze di un mercato estremamente dinamico e in costante evoluzione.

PRODUZIONE: APPARECCHI DI CONTROLLO PER FLUIDI

Gamma prodotti: pressostati, vuotostati, termostati, livellostati, flussimetri e flussostati, sonde di livello continue, indicatori elettronici programmabili, trasmettitori di pressione e pressostati elettronici, cappucci di protezione, connettori.

Sede Operativa e Centro Assistenza Clienti:
Milano, Via Jean Jaurés, 12.

Elettrotec, established in 1977 by Mr. Pietro Cremaschi, began first with the design and manufacturing of adjustable miniature pressure switches, electromagnetic float switches and electric flow indicators and switches with or without visual indication.

The fast and encouraging penetration in the market led the Company to direct its efforts towards investment aimed at steadily updating the products, keeping up with the progress in technology and always answering to any customer's requirements. During its 25 years of experience, years of radical changes and increasing competitiveness, Elettrotec has been able to improve and enlarge the product range with new series of level switches, flow indicators, pressure, vacuum and temperature switches, coming up to the expectations of the customers and the market in general, both in Italy and abroad.

Constant development and the attention paid to the fast changes required by the market are still an integral part of the Company policy. In fact, besides specific and custom-made solutions developed in years of experience, in 2002 the established Elettrotec core business was also added with two new product lines for the electronic industry. A challenge that the Company has to embark on, in order to expand its offer in all those applications requiring nowadays most accurate monitoring. Moreover, to give a comprehensive idea of the Elettrotec production, it has to be also mentioned a wide range of excellent accessories, such as protection caps and connectors, among which stands out in particular the new series of DIN connectors with transparent housing and red/green LED, designed to suit and fit not only the Elettrotec product range.

The huge investments and the great commitment yielded more than satisfactory results, letting Elettrotec become a primary actor in the field of instrumentation. Thanks to its high standard quality products, the Company is now very well-established in important sectors, such as: mechanical, pharmaceutical, medical, cosmetic, food, textile and healthcare industry, railway transportation, agricultural machinery, hydraulics, pneumatics, automation, lubrication plants, lifting systems, fire prevention, heat exchangers and earthwork machinery.

Elettrotec, certified according to UNI EN ISO 9001:2000, is characterized by team work. All the departments, from Marketing to the Shipping one, work closely together also well-aware to have to compete worldwide. This is the cornerstone of the Elettrotec organization, a structure that, according to the Management, is constantly growing and perfectly tuned with the requirements of an extremely dynamic market in a non-stop and progressive evolution.

PRODUCTION: CONTROL DEVICES FOR FLUIDS

Product range: pressure switches, vacuum switches, temperature switches, float level switches, flow indicators and switches, level sensors, programmable digital indicators, electronic pressure transmitters and switches, protection caps, connectors.

*Business Premises and Customer Service Centre:
Milan, Via Jean Jaurés, 12.*

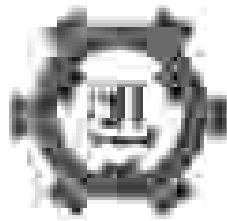

ELETTROTEC

S.R.L. MILANO

DATI TECNICI / TECHNICAL DATA

 RICH. OFFERTA
Inquiry OFFERTA
Offer LIVELLOSTATI ELETTROMAGNETICI
Electromagnetic level switches

DITTA/Company _____		TEL. _____		N./No _____	
VIA/Address _____		FAX _____		DATA/Date _____	
CAP/Zip Code _____ CITTÀ/Town _____		ATTNE/Attn _____			
<input type="checkbox"/> CLIENTE/Customer		VALIDITÀ OFFERTA/Offer validity		ESECUTORE/Executor	
<input type="checkbox"/> NUOVO CLIENTE/New Customer		COND. PAGAMENTO/Payment terms			
CARATTERISTICHE DEL FLUIDO/Fluid characteristics					
Tipo di fluido e PH/Type of fluid and PH					
Peso specifico/Specific weight				Kg/dm ³	
Viscosità/Viscosity				<input type="checkbox"/> Cst <input type="checkbox"/> mPa.s.	
Temperatura min-max/Min./max temperature				°C	
Temperatura esercizio/Operating temperature				°C	
Pressione esercizio/Operating pressure				bar	
Pressione min-max/Max pressure				bar	
Composizione del fluido/Composition of fluid					
Particelle in sospensione/Particles in suspension				micron	
DATI TECNICI ELETTRICI/Electrical data					
Lunghezza asta/Length		A...		mm	
N. punti di intervento/No. of switching points		1°	2°	3°	4°
Distanza contatti mm./Contact distance in mm.		A...	B...	C...	D...
Tipo di contatto a riposo (senza fluido)/ Contact (without fluid)		<input type="checkbox"/> NA/NO NC/NC	<input type="checkbox"/> NA/NO NC/NC	<input type="checkbox"/> NA/NO NC/NC	<input type="checkbox"/> NA/NO NC/NC
Tipo di carico elettrico/Electric load		<input type="checkbox"/> Induttivo/ Inductive	<input type="checkbox"/> Resistivo/ Resistive	<input type="checkbox"/> Elettronico/ Electronic	<input type="checkbox"/> SPDT
Tipo di protezione/Protection		<input type="checkbox"/> IP 54	<input type="checkbox"/> IP 65		
Intensità di corrente/Current				A	
Tensione di lavoro/Operating voltage				<input type="checkbox"/> V dc / cc	<input type="checkbox"/> V ca / ac
Potenza commutabile/Commutated power				Watt	
Distanza da campi magnetici mm./Distance from magnetic fields in mm.		<input type="checkbox"/> 50	<input type="checkbox"/> 100	<input type="checkbox"/> 200	<input type="checkbox"/> 500
		<input type="checkbox"/> > 500			
TIPI MATERIALI DEI COMPONENTI/Materials					
Tipo materiale flangia/Flange		<input type="checkbox"/> Alluminio Aluminium	<input type="checkbox"/> Inox 304 304 stainless steel	<input type="checkbox"/> PVC	
Tipo materiale asta/Stem		<input type="checkbox"/> Ottone Brass	<input type="checkbox"/> Inox 316 316 stainless steel	<input type="checkbox"/> PVC	
Tipo materiale galleggiante/Float		<input type="checkbox"/> NBR	<input type="checkbox"/> Inox 316 316 stainless steel	<input type="checkbox"/> PVC	
Cavi di collegamento int./Inside connection cables		<input type="checkbox"/> PVC	<input type="checkbox"/> Silicone Silicone	<input type="checkbox"/>	
Dimensione attacco filettato/Thread connection		<input type="checkbox"/> G 1/8	<input type="checkbox"/> G 1/4	<input type="checkbox"/> G 3/8	<input type="checkbox"/> G 1/2
		<input type="checkbox"/> G 3/4	<input type="checkbox"/> G 1	<input type="checkbox"/> G 1 1/4	<input type="checkbox"/> G 1 1/2
		<input type="checkbox"/> G 2			
NOTE					
TIPO PRODOTTO/Model		CODICE/Code	N. PEZZI/Pcs	PREZZO Cad./ Unit Price	SCONTO/Disc.
					CONSEGNA/ Delivery

LIVELLOSTATI ELETTROMAGNETICI

Float level switches

IMPIEGO

I livellostati elettromagnetici sono stati realizzati per controllare il livello di fluidi come acqua, oli minerali, gasolio, solventi, acidi ecc. contenuti in un serbatoio ed inviare un segnale elettrico di allarme di min o max livello su quadro di controllo. Vengono normalmente utilizzati nei settori della oleodinamica, lubrificazione, impiantistica, stoccaggio fluidi, veicoli industriali, elettrogeni, ecc.

FUNZIONAMENTO

A seconda dei vari modelli il livellostato deve essere fissato verticalmente sul coperchio del serbatoio del fluido da controllare, lontano almeno 50 mm da eventuali pareti laterali ferromagnetiche con asta di adatta lunghezza "A", che ha nel suo interno uno o più interruttori reed magnetici, lungo la quale scorre il galleggiante con magneti permanente. Nella fase di scorrimento lungo l'asta, il galleggiante va ad azionare uno o più contatti reed, determinando la chiusura del contatto "NC" nella versione LM1... con il galleggiante a riposo, cioè in basso, oppure lo scambio nelle versioni LM2... e SC. Abbiamo studiato dei livellostati "set da completare" e cioè LM1/2P/B/F che sono costituiti dalla testina superiore di fissaggio a flangia o con dado, che comprende: la basetta, il connettore, per realizzare i collegamenti elettrici con il livellostato tipo LM1S (un contatto) o LM2S (con contatto in scambio), da cui fuoriescono i cavi di collegamento. Per mezzo di un tubo di ottone o inox Ø 6 x 8 di lunghezza tale da realizzare il livellostato con la lunghezza "A" desiderata, si collegano alla parte superiore di fissaggio con il livellostato mediante il bocchettone e anello di serraggio BCH8-ANS8 e il raccordo e il bicono R8-B8. **Nei modelli LMD1 - LM1A - LM1FA - LM1P/F - LM1B/F - LMM1A/FA, è sufficiente invertire il galleggiante ruotandolo di 180°C per invertire il contatto da NC a NA, con il galleggiante a riposo.** Nelle versioni sopraccitate per avere la reversibilità di funzionamento con "un contatto" il galleggiante rimane durante il funzionamento sempre immerso nel fluido e può comportare nel tempo un problema al normale funzionamento, in quanto le microimpurità ferromagnetiche che vengono catturate dai magneti alloggiati nel galleggiante unitamente a quelle che naturalmente vi si depositano sopra, possono impedire il normale galleggiamento e causare il mancato funzionamento del livellostato con le inevitabili conseguenze.

A causa di ciò, poiché un dispositivo di controllo deve garantire la massima affidabilità di funzionamento nel tempo, abbiamo studiato le serie LM1CF - LM2CF - LMM1CF nelle versioni standard, con flangia in alluminio, asta in ottone, galleggiante NBR, e nella versione in acciaio inox, in cui il galleggiante scorre lungo l'asta sopra il livello da controllare ed il magnete non è a contatto con il liquido. È consigliabile per livellostati con asta di lunghezza superiore ad un metro, passare nelle versioni equivalenti LM1G - LM2G - LMM1G... strutturalmente più robuste.

COMPONENTI

Flangia di fissaggio in alluminio anodizzato, asta in ottone, galleggianti in resina espansa in NBR, oppure integralmente in acciaio inox.

DATI TECNICI PER I TIPI LMD1 - LM1... - LMM1...

Potenza commutabile in CC	60 W
Potenza commutabile CA	60 VA
Tensione max di lavoro	~220 V 50 Hz
Intensità di corrente max	0,8 A (resistivi)
Contatto a riposo (senza fluido)	NC
Capacità di contatti aperti	0,6 pF
Resistenza di isolamento del contatto	10 ¹⁰ ohm

DATI TECNICI PER I TIPI LMD2 - LM2... (contatto in scambio)

Potenza commutabile	30 W
Tensione di lavoro	~220 V 50 Hz
Intensità di corrente max	0,5 A (resistivi)
Capacità dei contatti	2 pF
Resistenza di isolamento del contatto	10 ⁹ ohm

DATI TECNICI COMUNI

Viscosità del fluido max	150 cSt
Pressione max	10 bar
Peso specifico	≥ 0,7
Connessione elettrica	PG9-DIN 43650
Protezione elettrica	IP65-DIN 40050
Temperatura di lavoro	-10 +80°C
Temperatura max con guarnizioni in Viton	+130 °C
Fissaggio	verticale
Inclinazione max	15°

N.B.: Per carichi elettrici induttivi, impiegare il circuito di protezione o il relè.

Per fluidi turbolenti incamiciare il livellostato con un tubo magnetico aperto sul fondo.

Applicare il livellostato distante almeno 50 mm. da pareti o corpi ferrosi e lontano da campi magnetici interagenti.

USE

These electromagnetic level indicators have been designed to monitor the level of a fluid, as water, gas, oil, solvents, acids and so on, in a tank and send an electric alarm signal of min. or max. level to a control panel. Eletrotec float switches are generally used in hydraulics, lubrication systems, plant engineering, fluid stocking, industrial vehicles, power units, etc.

OPERATION

According to the different models, Eletrotec level indicators have to be mounted vertically from tank top, at least 50-mm far from possible ferromagnetic side walls. The float encircling a stationary stem of proper length is equipped of a permanent magnet. As the float rises or lowers with liquid level, the magnetic field generated from within the float actuates one or more hermetically sealed reed switches mounted within the stem, i.e. contacts will close/open in LM1... models (Normally Closed dry condition) and change over in LM2...(SPDT dry condition). Custom level switch kits are available to assemble complete indicators in minutes. LM1/2P/B/F kits contain a flange or threaded mounting plug housing the terminal board necessary to connect level stations LM1S (one contact) or LM2S (C/O contact), tube connector BCH8-ANS8, tube union and end fitting R8 -B8 to build, using a brass or stainless steel stem, a level indicator of the required length. **LMD1 - LM1A - LM1FA - LM1P/F - LM1B/F - LMM1A/FA single point switches operate in either N/C or N/O mode. It is only necessary to reverse the float on the stem to select the mode required. Eletrotec switches are shipped Normally Closed as standard.** In the above mentioned models the float, while working, is always immersed in the media. This could cause working problems in time, because ferromagnetic particulate and debris captured by the magnets housed inside the float could affect proper operation and floating. Since a control device has to assure working reliability, Eletrotec has developed LM1CF - LM2CF - LMM1CF models where the float with magnet sliding along the stem over the liquid level to be monitored is not in contact with the fluid. For level indicators longer than 1m., it is advisable to choose the LM1G - LM2G - LMM1G models with rugged construction.

MATERIALS

Fastening flange in anodized aluminium, brass stem, NBR. Float or stainless steel execution available.

TECHNICAL DATA - MODELS LMD1 - LM1... - LMM1...

Commutated Power DC	60 W
Commutated Power AC	60 VA
Max voltage	~220 V-50 Hz
Max intensity of current	0.8 A (resistive)
Idle contact (without fluid)	N/C
Open contact capacity	0.6 pF
Contact insulation resistance	10 ¹⁰ ohm

TECHNICAL DATA - MODELS LMD2 - LM2... (C/O contacts)

Commutated Power	30 W
Voltage	~220 V-50 Hz
Max intensity of current	0.5 A (resistive)
Contact capacity	2 pF
Contact insulation resistance	10 ⁹ ohm

STANDARD TECHNICAL DATA

Fluid viscosity	150 cSt
Maximum pressure	10 bar
Fluid specific weight	≥ 0.7
Electrical connection	PG9-DIN 43650
Electrical protection	IP65-DIN 40050
Temperature range	-10 +80°C
Gasket Viton max temperature	130°C
Fastening	vertical
Max tilt	15°

A protection circuit or relay is to be used for electrical inductive load.

For turbulent fluids, it is necessary to line the level indicator with a not magnetic tube, open on the bottom.

Fix the level indicator at least 50-mm. far from iron walls and bodies and from other interacting magnetic fields.

INFORMAZIONI TECNICHE

Technical information

CIRCUITI PROTETTIVI PER CONTATTI REED

I valori relativi alla portata della corrente e della tensione, indicati nei dati tecnici si riferiscono a carichi resistivi. Spesso, tuttavia, si devono controllare carichi induttivi o capacitativi, oppure si devono azionare lampade.

Per situazioni di questo tipo è necessaria qualche considerazione circa l'opportunità di proteggere i contatti reed dai picchi di tensione o di corrente.

1) Carichi induttivi

In presenza di circuiti alimentati con corrente continua, la protezione del contatto è relativamente facile. Si deve collegare in parallelo al carico un diodo semiconduttore come indicato nella fig. 1. Le polarità devono essere collegate in modo che il diodo si blocchi con il normale voltaggio di esercizio e sempre in corto circuito nel caso di inversione delle polarità.

Quando si commutano dei carichi induttivi, alimentati con corrente alternata, non si può utilizzare un diodo, bisogna usare un dispositivo di soppressione dell'arco RC. Di solito si tratta di un collegamento RC parallelo al commutatore e quindi in serie con il carico, come da fig. 2. La dimensione del soppressore di arco può essere determinata dal monogramma di fig. 3.

2) Carichi capacitivi e resistivi

Al contrario di quanto avviene con i carichi induttivi, con i carichi capacitativi e con lampada si hanno elevate scariche di corrente che possono provocare guasti immediati, e persino la saldatura dei contatti. Quando si commutano dei condensatori carichi o dei condensatori di linea, si ha un'immediata scarica la cui intensità dipende dalla portata e dalla lunghezza dei collegamenti. La corrente di scarica o di picco è limitata da un resistore in serie con il condensatore, come è indicato nella fig. 4. La dimensione del resistore sarà determinata in base alle possibilità esistenti nell'ambito di un particolare circuito. In ogni caso, dovrebbe essere il più grande possibile per limitare lo scarico di corrente entro limiti accettabili. Quando detto vale anche per il carico con condensatori.

Per quanto riguarda i circuiti con condensatori ad elevata scarica di corrente, andrebbero usati i circuiti come da fig. 5, con R_1 o R_2 .

Le lampade al tungsteno aumentano da 5 a 15 volte la corrente nominale durante i primi 10 milisecondi di funzionamento. Queste elevate scariche di corrente possono essere limitate entro valori accettabili con l'aggiunta di resistenze collegate in serie per limitare la corrente. Un'altra possibilità consiste nel collegare una resistenza in parallelo con il commutatore in modo che i filamenti delle lampade vengano pre-riscaldati proprio sino al punto in cui non diventano incandescenti quando vengono accese. Entrambi i metodi comportano una perdita di corrente.

PROTECTIVE CIRCUITS FOR REED CONTACTS

The values for current, voltage, and capacity as given in the technical data refer to pure resistive loads. However, inductive or capacity loads are often to be checked or lamps are to be switched.

In this case it is necessary to protect the reed contacts against peaks in voltage or current.

1) Inductive loads

The contact protection is relatively easy with direct current. A semiconductor diode is to be connected in parallel to the load, as indicated in picture 1.

Polarities must be connected in a way the diode would simply jam under normal operating voltage and always short-circuit the opposing voltage that occurs with the opening of the switch.

When inductive loads, fed with alternative current, are switched, it is not to be used a diode but an arc-suppression unit.

An RC link connected in parallel to the switch, and therefore in series with the load, is usually applied, see picture 2. The arc-suppression size can be taken from a chart, as from picture 3.

2) Capacity and Resistive loads

Contrary to inductive loads, high current inrushes occur with capacitive loads or switched-on lamps, and that may lead to early switch failure or even to welding of contacts.

When charged capacitors or cable capacitors are switched, a sudden discharge occurs, the intensity of which depends on the capacity and length of the connecting cables. A resistor in series with the capacitor limits the current peaks or discharges, as shown in picture 4.

The size of the resistor depends on the different possibilities offered by a particular circuit. In any case the resistor should be the biggest possible to limit the current discharge within acceptable values. The same applies also to charging of capacitors.

Protection against high current discharges from capacitors should be provided by means of the circuit R1 or R2 or both, as shown in picture 5.

Tungsten lamps increase from 5 to 15 times the rated current during their first ten milliseconds of working. These high current inrushes can be limited to an acceptable value connecting in series current-limiting resistances or connecting in parallel to the switch a resistance, so that the lamp filaments would be preheated just to the point they would not incandescent when turned on. Both protecting solutions imply a loss of power.

Monogramma per determinare la soppressione dell'arco di contatto per carichi induttivi.

Graph for determining the contact arc suppression for inductive loads.

Esempio 1: $I = 0,1 \text{ A}$
 $V_L = 220 \text{ V}$
 $C = 0,001 \mu\text{F}$
 $R = 340$

Example 1: $I = 0,1 \text{ A}$
 $V_L = 220 \text{ V}$
 $C = 0,001 \mu\text{F}$
 $R = 340$

Example 2:
 When the inrush current is critical, the resistance should be determined with the lower graph, for example inrush current 0.5 A
 $R_{\text{min}} = 400$

Esempio 2
 Quando la scarica di corrente è critica, la resistenza dovrebbe essere determinata con il monogramma più basso, ad esempio: scarica di corrente 0,5 A $R_{\text{min}} = 400$

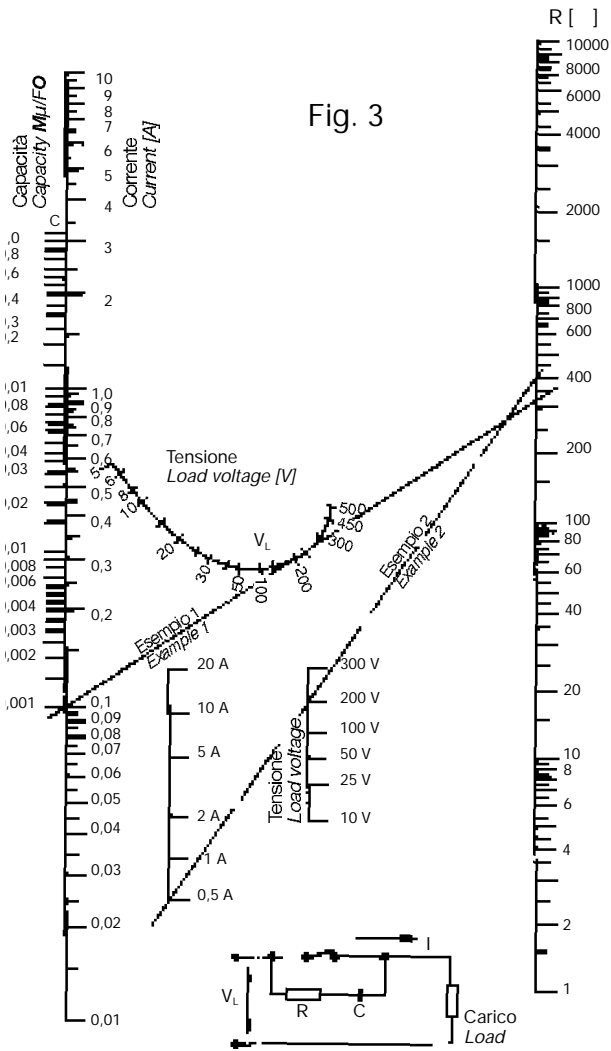

Fig. 3

Circuiti protettivi per contatti Reed Protective circuits for Reed contacts

Carichi induttivi Inductive loads

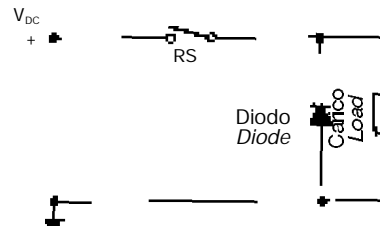

Fig. 1

Protezione con corrente continua per carichi induttivi.

Direct current protection with semiconductor diode for inductive loads.

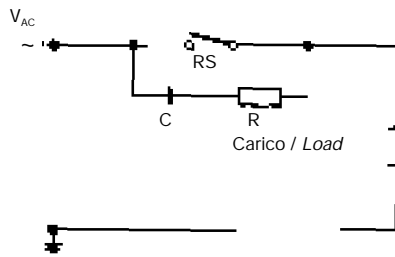

Fig. 2

Protezione con corrente alternata con collegamento RC per carico induttivo.

Alternating current protection with RC link for inductive load.

Carichi resistivi e capacitivi

Capacitive and Resistive Loads

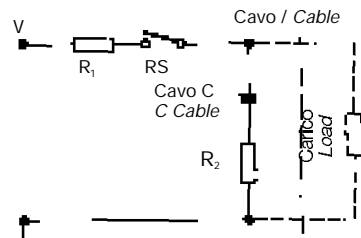

Fig. 4

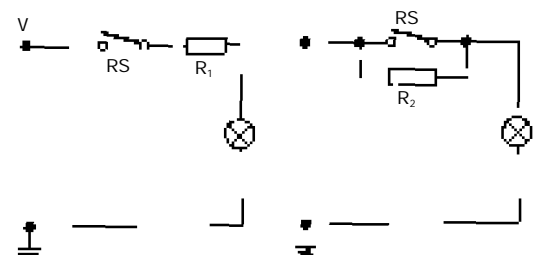

Fig. 5

Circuito con lampada, resistenza in parallelo o in serie con il commutatore.

Lamp load resistance in parallel or in series with switch.

Filtro dimensionato con il collegamento RC

Arc suppressor with RC link

LIVELLOSTATI ELETTROMAGNETICI

Electromagnetic level indicators

Type LEM5...

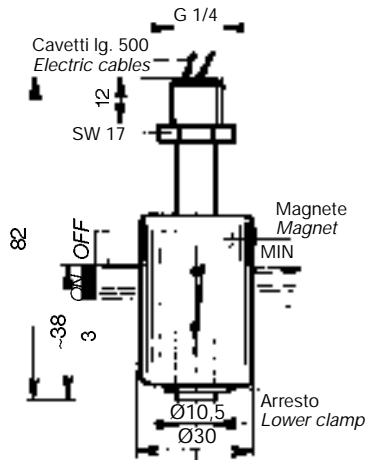

Code 3.2.510
Type LEM5CN

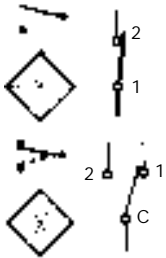

Code 3.2.511
Type LEM5CNSc

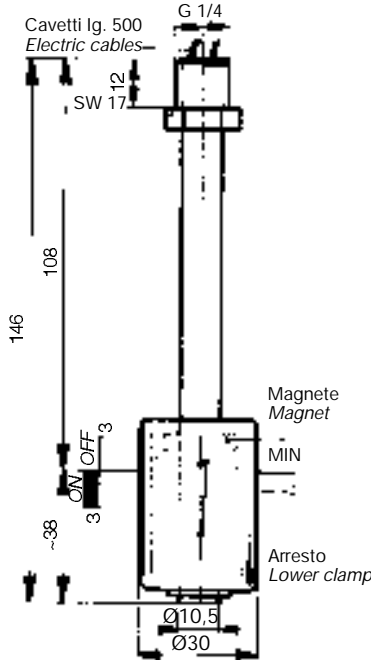

Code 3.2.514
Type LEM5LN

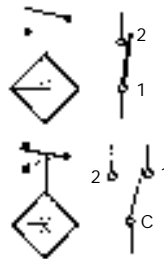

Code 3.2.515
Type LEM5LNSc

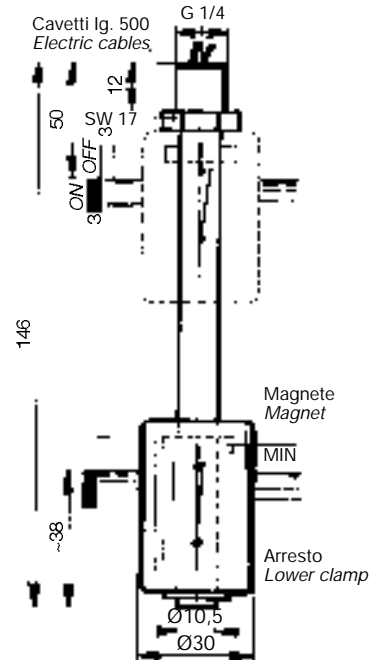

Code 3.2.520
Type LEM5M

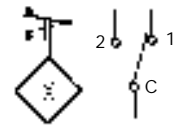

IMPIEGO

Sono stati studiati per controllare il minimo o il massimo livello dell'olio, acqua, solventi contenuti, in un serbatoio e per inviare a distanza un segnale elettrico. A seconda dei tipi, devono essere applicati sul coperchio del serbatoio con giacitura verticale in modo che il galleggiante disti almeno 50 mm dalle pareti metalliche.

DATI TECNICI

Potenza commutabile in CC	60 W
Potenza commutabile in CA	60 VA
Intensità di corrente	0.8 A (resistivi)
Tensione max. di lavoro	220 V - 50 Hz
Tensione di breakdown	300 V
Capacità dei contatti aperti	0,6 pF
Campo di temperatura	-10 +80°C
Resistenza d'isolamento	10 ¹⁰ OHM

CON CONTATTI SPDT "Sc"

Potenza commutabile	30 W
Corrente commutabile	0.5 A (resistivi)
Resistenza d'isolamento	10 ⁹ OHM min.
Capacità dei contatti	2 pF
Peso specifico liquido	≥ 0,7
Pressione massima	5 Bar
Viscosità del fluido	max 150 cSt
Costruzione	Nylon nero monocorpo galleggiante in resina espansa NBR

USE

This series of electromagnetic level indicators has been designed to check the minimum or maximum level of oil, water, solvents in a tank and send an electric signal to a remote board in case the fluid goes over or under the set levels. These level indicators should be fixed vertically on the cover of the tank, with the float at least 50 mm far from metal walls.

TECHNICAL DATA

Power commutated in DC	60 W
Power commutated in AC	60 VA
Intensity of current	0.8 A (resistive)
Voltage	220 V - 50 Hz
Breakdown voltage	300 V
Open contacts capacity	0,6 pF
Temperature range	-10 +80°C
Insulation resistance	10 ¹⁰ OHM

WITH SPDT CONTACTS "Sc"

Power commutated	30 W
Intensity of current	0.5 A (resistive)
Insulation resistance	10 ⁹ OHM min.
Open contacts capacity	2 pF
Fluid specific weight	≥ 0,7
Maximum pressure	5 Bar
Fluid viscosity	max 150 cSt
Material	compact nylon black body; NBR expanded resin float.

PER CARICHI INDUTTIVI IMPIEGARE CIRCUITO DI PROTEZIONE.

WITH INDUCTIVE LOADS A PROTECTION CIRCUIT IS TO BE USED.

LIVELLOSTATI ELETTROMAGNETICI

Electromagnetic level indicators

ATOSSICI-ATOXIC

Type LEM5...A

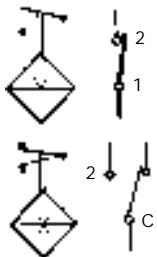
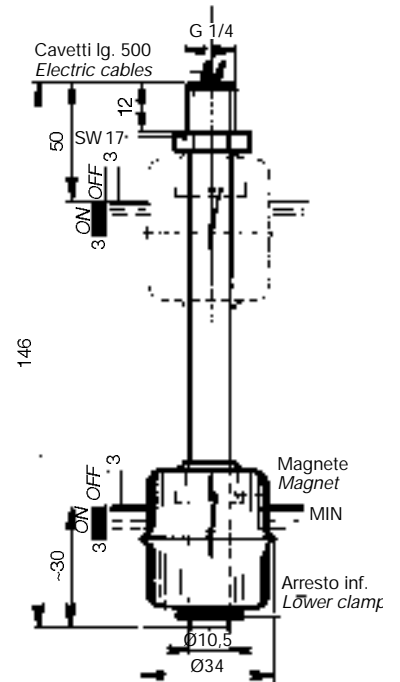
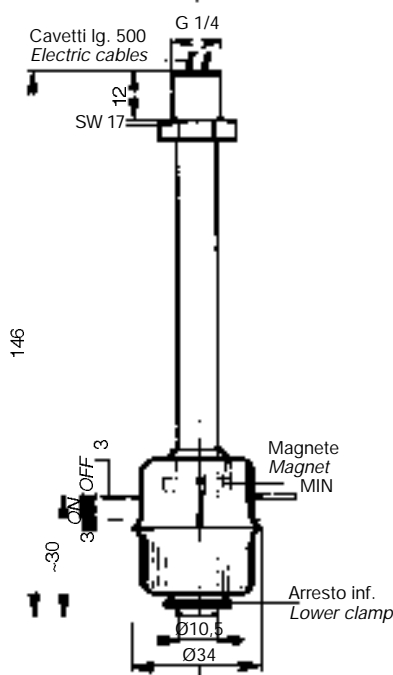
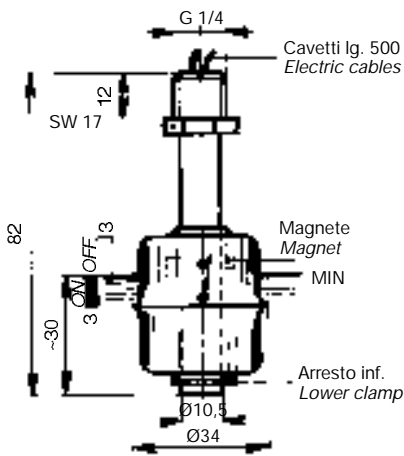

Code 3.2.512
Type LEM5CA

Code 3.2.513
Type LEM5CAsC

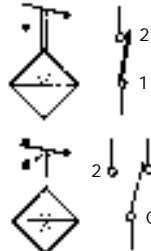

Code 3.2.516
Type LEM5LA

Code 3.2.517
Type LEM5LAsC

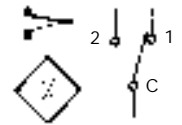

Code 3.2.521
Type LEM5MA

IMPIEGO

Sono stati studiati per controllare il minimo o il massimo livello dell'olio, acqua, solventi, in un serbatoio e inviare a distanza un segnale elettrico. A seconda dei tipi, devono essere applicati sul coperchio del serbatoio con giacitura verticale in modo che il galleggiante disti almeno 50 mm dalle pareti metalliche.

DATI TECNICI

Potenza commutabile in CC 60 W
Potenza commutabile in CA 60 VA
Intensità di corrente 0.8 A (resistivi)
Tensione max. di lavoro 220 V - 50 Hz
Tensione di breakdown 300 V
Capacità dei contatti aperti 0,6 pF
Campo di temperatura -10 +80°C
Resistenza d'isolamento 10¹⁰ OHM

CON CONTATTI SPDT "Sc"

Potenza commutabile 30 W
Corrente commutabile 0.5 A (resistivi)
Resistenza d'isolamento 10⁹ OHM min.
Capacità dei contatti 2 pF
Peso specifico liquido ≥ 0,7
Pressione massima 5 Bar
Viscosità del fluido max 150 cSt
Costruzione Corpo atossico
bianco, galleggiante inox 316, esecuzione stagna.

USE

This series of electromagnetic level indicators has been designed to check the minimum or maximum level of oil, water, solvents in a tank and send an electric signal to a remote board in case the fluid goes over or under the set levels. These level indicators should be fixed vertically on the cover of the tank, with the float at least 50 mm far from metal walls.

TECHNICAL DATA

Power commutated in DC 60 W
Power commutated in AC 60 VA
Intensity of current 0.8 A (resistive)
Voltage 220 V - 50 Hz
Breakdown voltage 300 V
Open contacts capacity 0,6 pF
Temperature range -10 +80°C
Insulation resistance 10¹⁰ OHM

WITH SPDT CONTACTS "Sc"

Power commutated 30 W
Intensity of current 0.5 A (resistive)
Insulation resistance 10⁹ OHM min.
Open contacts capacity 2 pF
Fluid specific weight ≥ 0,7
Maximum pressure 5 Bar
Fluid viscosity max 150 cSt
Material atoxic white body;
316 stainless steel float;
sealed manufacture.

PER CARICHI INDUTTIVI IMPIEGARE CIRCUITO DI PROTEZIONE.

WITH INDUCTIVE LOADS A PROTECTION CIRCUIT IS TO BE USED.

LIVELLOSTATI ELETTROMAGNETICI

Electromagnetic level indicators

Type LEM6...

IMPIEGO

Sono stati studiati per controllare il minimo o il massimo livello dell'olio, acqua, solventi, in un serbatoio e per inviare a distanza un segnale elettrico. A seconda dei tipi, devono essere applicati sul coperchio del serbatoio con giacitura verticale in modo che il galleggiante disti almeno 50 mm. dalle pareti metalliche.

DATI TECNICI COMUNI

Campo di temperatura	-10°+80°C
Pressione massima	5bar
Peso specifico fluido	0,7
Viscosità max. del fluido	150 cSt
Costruzione LEM 6	Nylon nero monocolpo Galleggiante in resina espansa NBR Corpo atossico bianco, galleggiante inox 316 Esecuzione stagna

Costruzione LEM 6 Atossico

DATI TECNICI VERSIONE CONTATTO NC

Potenza commutabile in CC	10 W
Potenza commutabile in CA	10 VA
Intensità di corrente	0,5A (resistivo)
Tensione massima di lavoro	220 V - 50 Hz
Tensione di breakdown	300 Vdc
Capacità dei contatti aperti	0,2pF
Resistenza d'isolamento	10 ¹⁰

DATI TECNICI VERSIONE CONTATTO SPDT E NA

Potenza commutabile in CC	3 W
Potenza commutabile in CA	3 VA
Intensità di corrente	0,25A (resistivo)
Tensione massima di lavoro	175 Vdc
Tensione di breakdown	200 Vdc
Capacità dei contatti aperti	1pF
Resistenza d'isolamento	10 ⁹

PER CARICHI INDUTTIVI IMPIEGARE CIRCUITO DI PROTEZIONE.

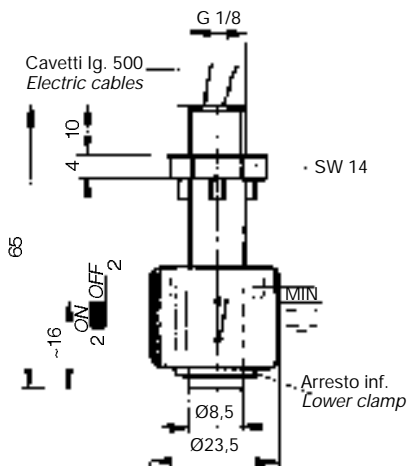

Simbolo
Symbol

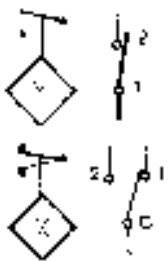

Code 3.2.530
Type LEM6CN

Code 3.2.531
Type LEM6CNSc

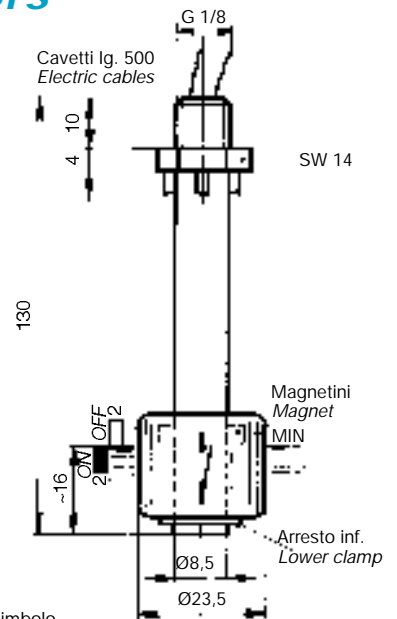

Simbolo
Symbol

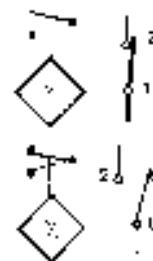

Code 3.2.534
Type LEM6LN

Code 3.2.535
Type LEM6LNSc

LIVELLOSTATI ELETTROMAGNETICI - ATOSSICI

Electromagnetic level indicators - ATOXIC

LEM6A-LEM6ASC

USE

This series of electromagnetic level indicators has been designed to check the minimum or maximum level of oil, water, solvents in a tank and send an electric signal to a remote board in case the fluid goes over or under the set levels. These level indicators should be fixed vertically on the cover of the tank, with the float at least 50 mm far from metal walls.

STANDARD TECHNICAL DATA

Temperature range	-10°+80°C
Maximum pressure	5bar
Fluid specific weight	0,7
Max. fluid viscosity	150 cSt
LEM 6 material	Compact nylon black body NBR expanded resin float Atoxic white body, 316 stainless steel float, Sealed manufacture

Atoxic LEM 6 material

NC CONTACT VERSION TECHNICAL DATA

Power commutated in DC	10 W
Power commutated in AC	10 VA
Intensity of current	0,5A (resistive)
Voltage	220 V - 50 Hz
Breakdown voltage	300 Vdc
Open contact capacity	0,2pF
Insulation resistance	10 ¹⁰

SPDT AND NO CONTACT VERSION TECHNICAL DATA

Power commutated in DC	3 W
Power commutated in AC	3 VA
Intensity of current	0,25A (resistive)
Voltage	175 Vdc
Breakdown voltage	200 Vdc
Open contact capacity	1pF
Insulation resistance	10 ⁹

WITH INDUCTIVE LOADS A PROTECTION CIRCUIT IS TO BE USED.

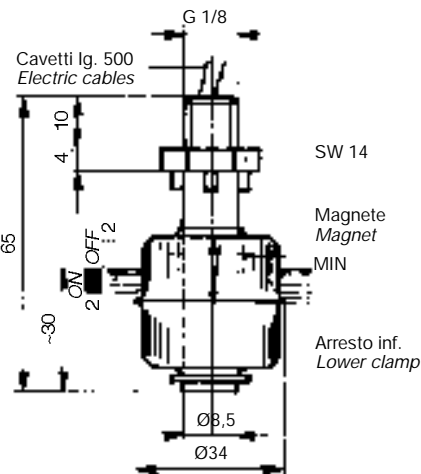

Simbolo
Symbol

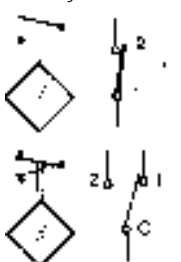

Code 3.2.532
Type LEM6CA

Code 3.2.533
Type LEM6CASC

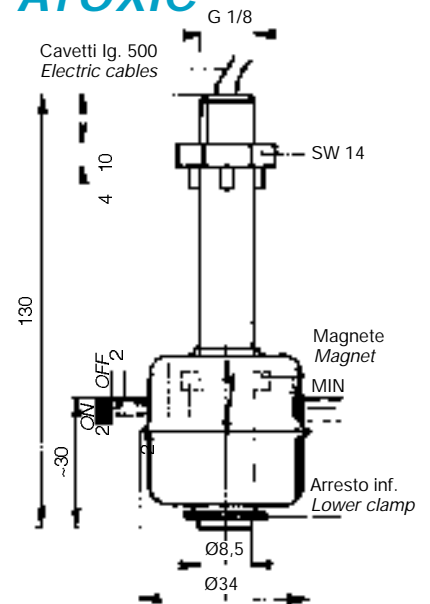

Simbolo
Symbol

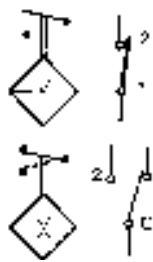

Code 3.2.536
Type LEM6LA

Code 3.2.537
Type LEM6LASC

LIVELLOSTATI ELETTROMAGNETICI

Electromagnetic level indicators

Type LMD - LM

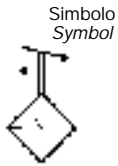
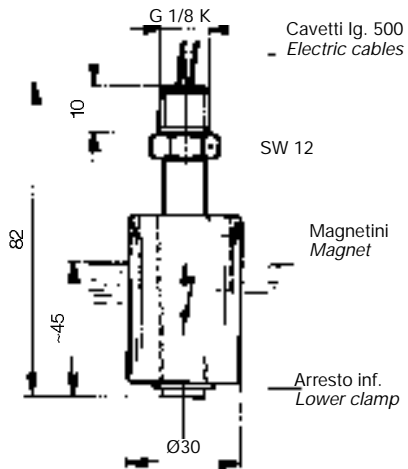

Code 3.2.000 - Type LMD1

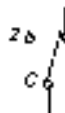

Code 3.2.001 - Type LMD2

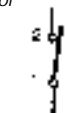
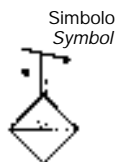
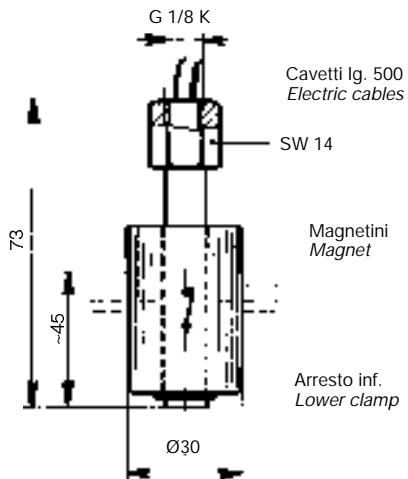

Code 3.2.011 - Type LM1

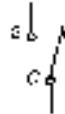

Code 3.2.012 - Type LM2

COSTRUZIONE: raccordo e tubo in ottone, galleggiante in NBR espansa.

IMPIEGO E DATI TECNICI (vedere pag. 1 - 2 - 3).

MATERIAL: brass fitting and tube; float in NBR expanded resin.

APPLICATION AND TECHNICAL DATA (see page 1 - 2 - 3).

LIVELLOSTATI ELETTROMAGNETICI SET DA COMPLETARE

Electromagnetic level indicators - Set to be completed

Code 3.2.015 - Type LM1P



Code 3.2.017 - Type LM1PF

Code 3.2.016 - Type LM2P



Code 3.2.018 - Type LM2PF

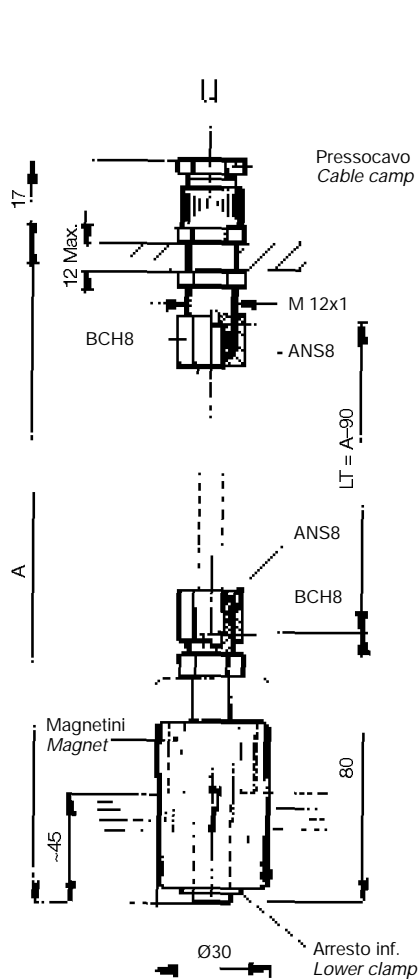

Schema di applicazione
Application chart

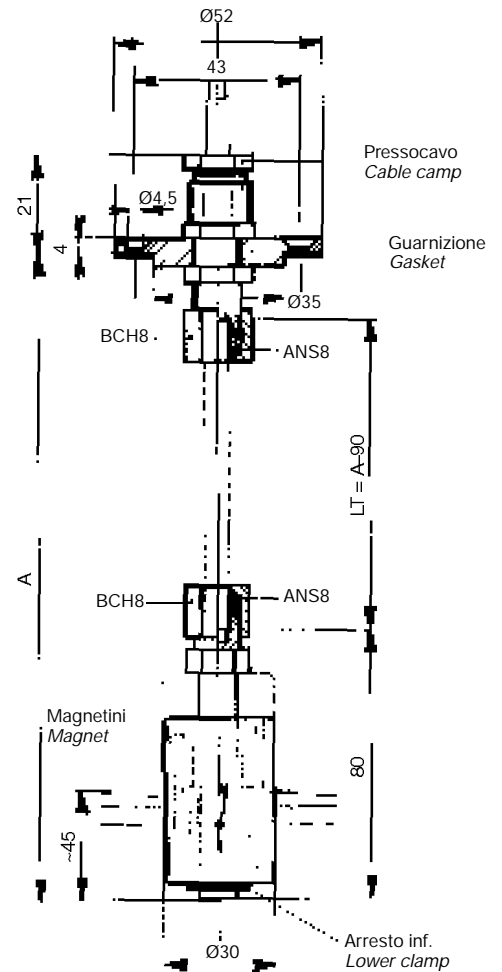
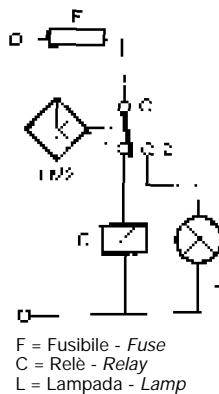

COSTRUZIONE: flangia in alluminio anodizzato, raccordo pressacavo in ottone, bocchettone in ottone BCH8, anello di serraggio ANS8, galleggiante NBR.

IMPIEGO E DATI TECNICI (vedere pag. 1 - 2 - 3).

N.B. - Per un corretto funzionamento, serrare con cura i raccordi BCH8 in modo da ottenere un buon fissaggio e tenuta del tubo di ottone Ø 6 x 8, onde evitare infiltrazioni d'olio nel livellostato e comprometterne il funzionamento.

MATERIAL: flange in anodized aluminium, fitting cable clamp in brass, BCH8 brass fittings, ANS8 fastening ring NBR float.

APPLICATION AND TECHNICAL DATA (see page 1 - 2 - 3).

N.B. - For a correct operation, fasten carefully the BCH8 pipe fittings to obtain a firm seal of the Ø 6 x 8 brass pipe and to avoid oil leakage in the level indicator thus affecting its working.

LIVELLOSTATI ELETTROMAGNETICI SET DA COMPLETARE

Electromagnetic level indicators - Set to be completed

Code 3.2.040 - Type LM1B
Code 3.2.041 - Type LM2B

Code 3.2.046 - Type LM1BF
Code 3.2.047 - Type LM2BF

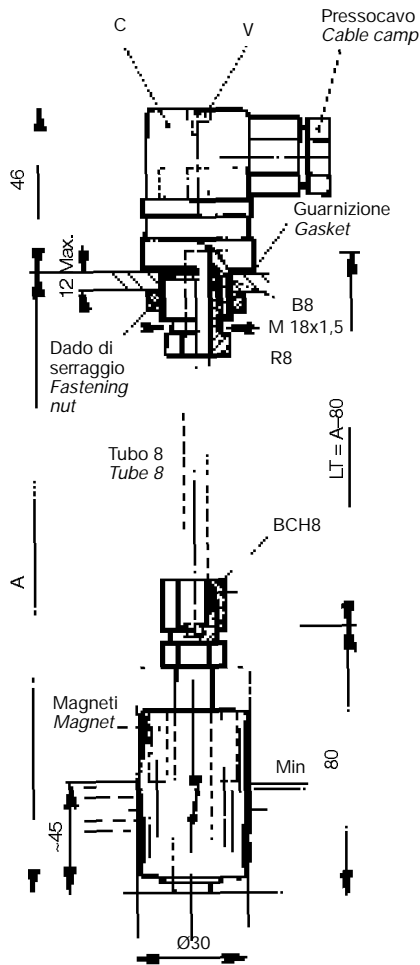

Schema di applicazione
Application chart

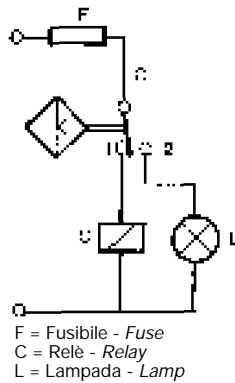

Collegamenti elettrici
Electrical connection

LM1B

Simboli
Symbol

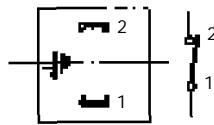

LM2B

Simboli
Symbol

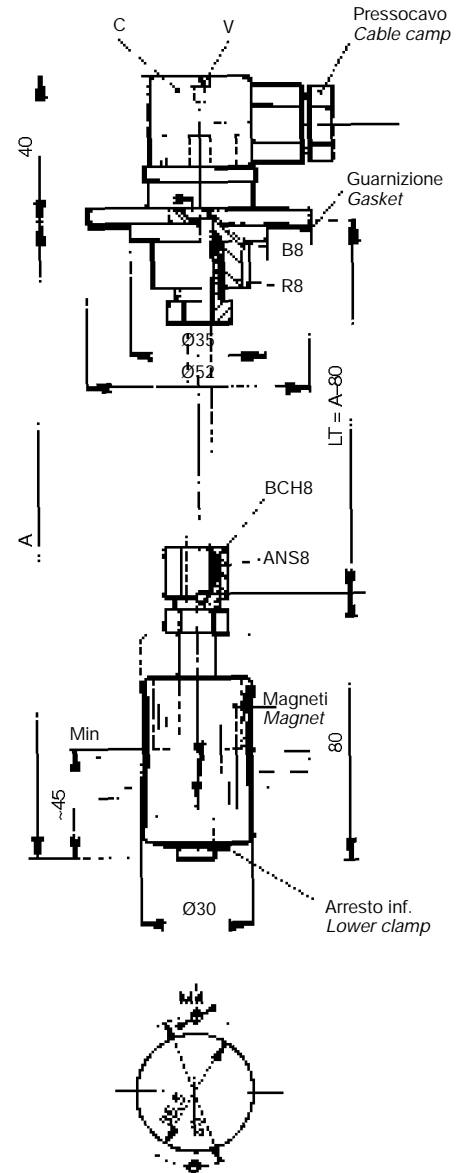
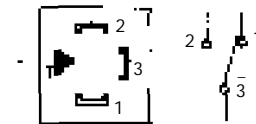

COSTRUZIONE: flangia in alluminio anodizzato, corpo in ottone, molla e anelli di arresto in bronzo, galleggiante in resina espansa NBR.

IMPIEGO E DATI TECNICI (vedere pag. 1 - 2 - 3).

N.B. - Per un corretto funzionamento, serrare con cura i raccordi BCH8 e R8 in modo da ottenere un buon fissaggio e tenuta del tubo di ottone Ø 6 x 8, onde evitare infiltrazioni d'olio nel livellostato e comprometterne il funzionamento.

MATERIAL: flange in anodized aluminium, brass body, bronze spring and stop rings, NBR float.

APPLICATION AND TECHNICAL DATA (see page 1 - 2 - 3).

N.B. - For a correct operation, fasten carefully the BCH8 and the R8 pipe fittings to obtain a firm seal of the Ø 6 x 8 brass pipe and to avoid oil leakage in the level indicator thus affecting its working.

LIVELLOSTATI ELETTROMAGNETICI

Electromagnetic level indicators

Type LM1A
LM2A

Type LMM1A...

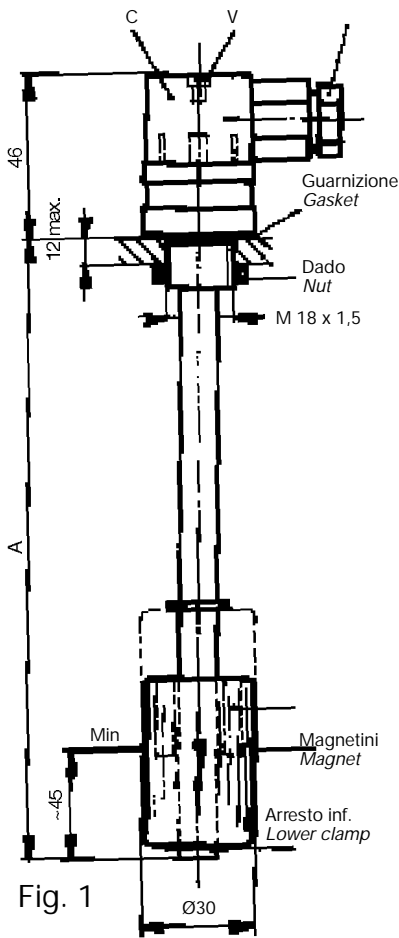

Collegamenti elettrici
Electrical connection

Simboli
Symbol

LM1

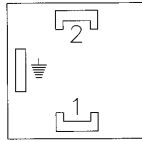
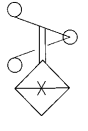

Simboli
Symbol

LM2

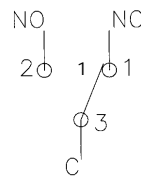
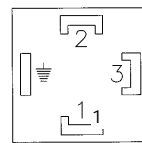
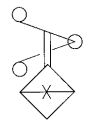

Simboli
Symbol

LMM1

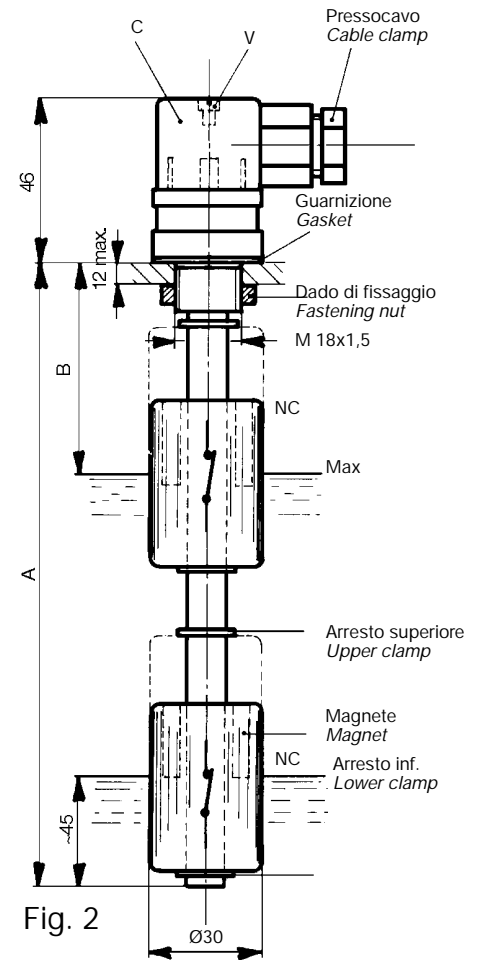
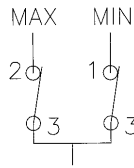
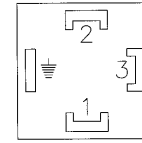
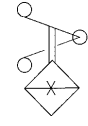

COSTRUZIONE: flangia filettata in alluminio anodizzato, tubo in ottone, molla e anelli di arresto in bronzo, galleggiante in resina espansa NBR.

MATERIAL: threaded flange in anodized aluminium, brass tube, spring and stop ring in bronze, NBR expanded resin float.

IMPIEGO E DATI TECNICI
(vedere pag. 1 - 2 -3).

APPLICATION AND TECHNICAL DATA
(see page 1 - 2 -3).

N.B. - A richiesta, forniamo lunghezze superiori, oppure diverse da quelle indicate in tabella.

N.B. - On customer's request superior or different lengths from those indicated in the reference table can be supplied.

FIGURA 1 Picture 1		FIGURA 2 Picture 2		
		A	B	
TIPO Type	TIPO Type			TIPO Type
LM1A100	LM2A100	100		
LM1A150	LM2A150	150		
LM1A200	LM2A200	200	60	LMM1A200B60
LM1A250	LM2A250	250	60	LMM1A250B60
LM1A300	LM2A300	300	60	LMM1A300B60
LM1A350	LM2A350	350	60	LMM1A350B60
LM1A400	LM2A400	400	70	LMM1A400B70
LM1A450	LM2A450	450	70	LMM1A450B70
LM1A500	LM2A500	500	80	LMM1A500B80

LIVELLOSTATI ELETTROMAGNETICI

Electromagnetic level indicators

Type LM1FA
LM2FA

Type LMM1FA...

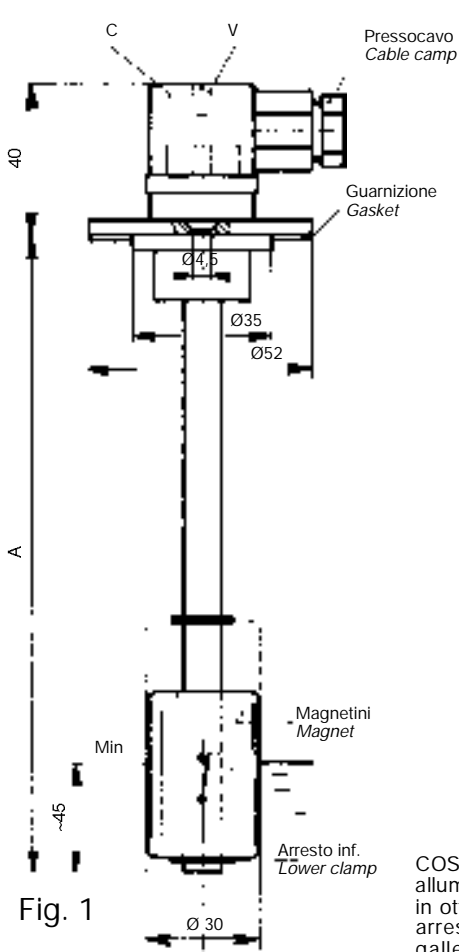
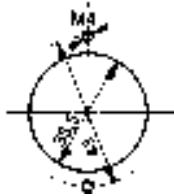

Fig. 1



Collegamenti elettrici
Electrical connection

Simboli
Symbol

LM1

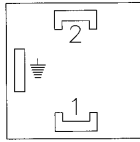

Simboli
Symbol

LM2

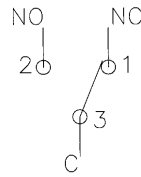
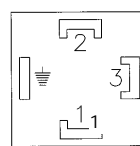

Simboli
Symbol

LMM1

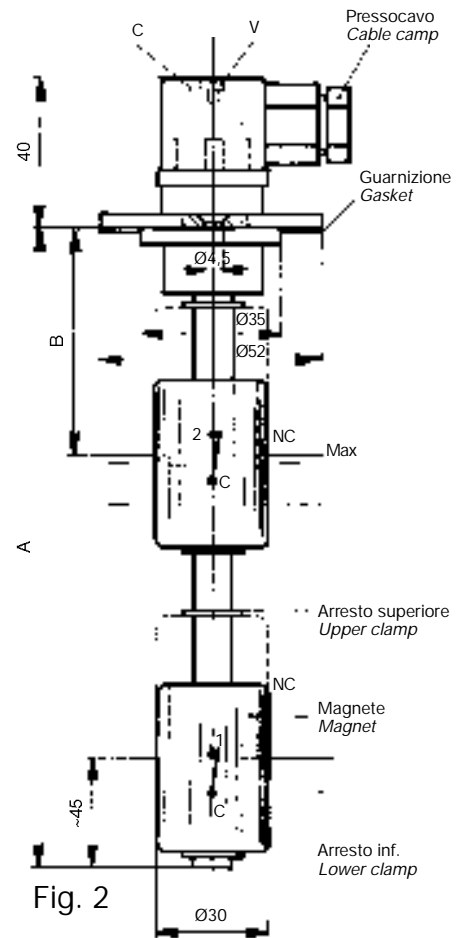
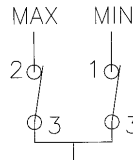
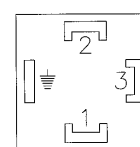

Fig. 2



COSTRUZIONE: flangia in alluminio anodizzato, tubo in ottone, molla e anelli di arresto in bronzo, galleggiante in resina espansa NBR.

MATERIAL: threaded flange in anodized aluminium, brass tube, spring and stop ring in bronze. NBR expanded resin float.

IMPIEGO E DATI TECNICI
(vedere pag. 1 - 2 - 3).

APPLICATION AND TECHNICAL DATA
(see page 1 - 2 - 3).

N.B. - A richiesta, forniamo lunghezze superiori, oppure diverse da quelle indicate in tabella.

N.B. - On customer's request superior or different lengths from those indicated in the reference table can be supplied.

FIGURA 1 Picture 1		FIGURA 2 Picture 2		
		A	B	
TIPO Type	TIPO Type			TIPO Type
LM1FA100	LM2FA100	100		
LM1FA150	LM2FA150	150		
LM1FA200	LM2FA200	200	60	LMM1FA200B60
LM1FA250	LM2FA250	250	60	LMM1FA250B60
LM1FA300	LM2FA300	300	60	LMM1FA300B60
LM1FA350	LM2FA350	350	60	LMM1FA350B60
LM1FA400	LM2FA400	400	70	LMM1FA400B70
LM1FA450	LM2FA450	450	70	LMM1FA450B70
LM1FA500	LM2FA500	500	80	LMM1FA500B80

LIVELLO STATI ELETTROMAGNETICI

Electromagnetic level indicators

Type LM1TA...
LM2TA...

Type LMM1TA...

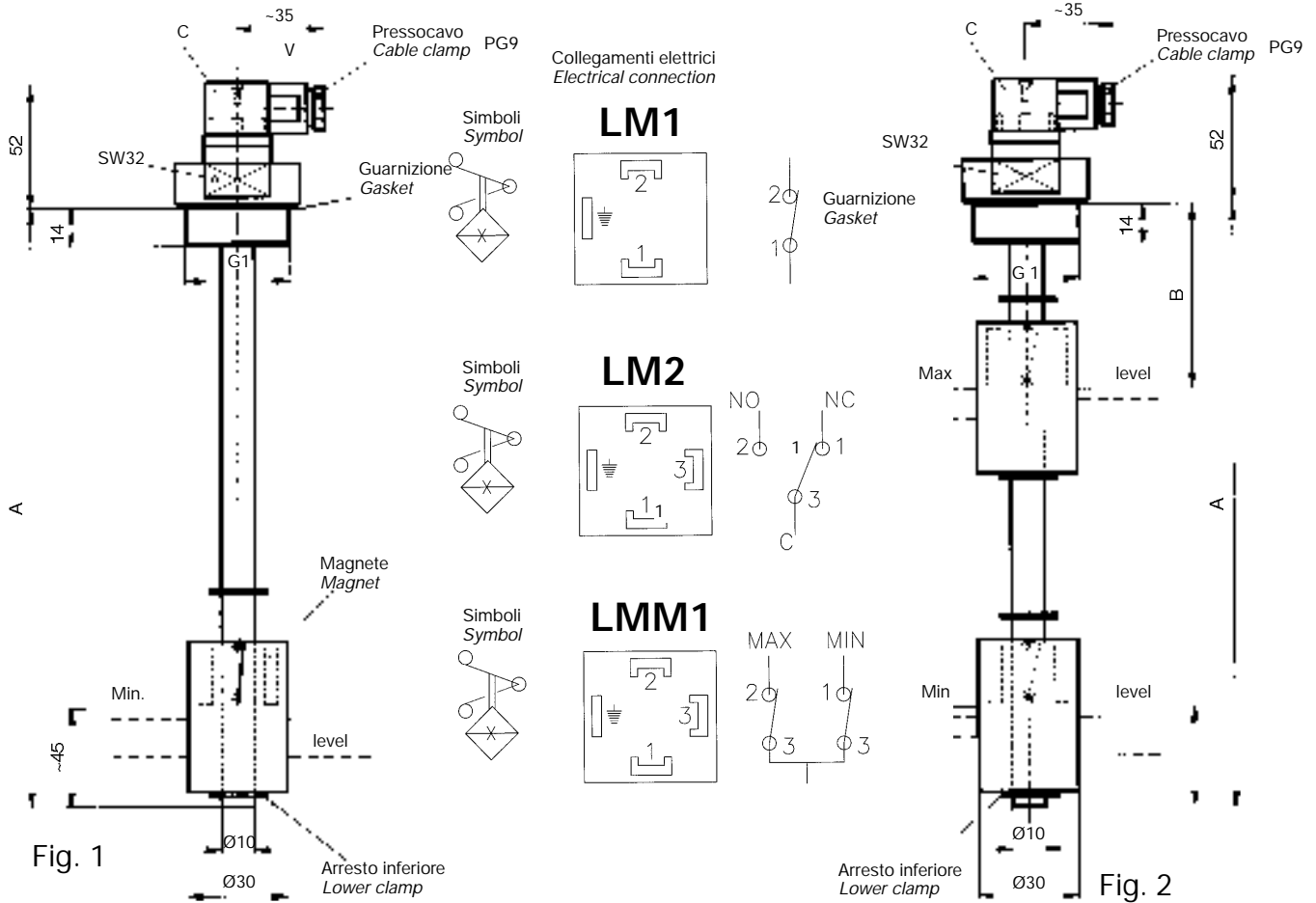

COSTRUZIONE: flangia filettata in alluminio anodizzato, tubo in ottone, molla e anelli di arresto in bronzo, galleggiante in resina espansa NBR.

MATERIAL: threaded flange in anodized aluminium, brass tube, spring and stop ring in bronze. NBR expanded resin float.

IMPIEGO E DATI TECNICI
(vedere pag. 1 - 2 -3).

APPLICATION AND TECHNICAL DATA
(see page 1 - 2 -3).

N.B. - A richiesta, forniamo lunghezza superiori, oppure diverse da quelle indicate in tabella.

N.B. - On customer's request superior or different lengths from those indicated in the reference table can be supplied.

FIGURA 1 Picture 1		FIGURA 2 Picture 2		
		A	B	
TIPO Type	TIPO Type			TIPO Type
LM1TA150	LM2TA150	150		
LM1TA200	LM2TA200	200	60	LMM1TA200B60
LM1TA250	LM2TA250	250	60	LMM1TA250B60
LM1TA300	LM2TA300	300	60	LMM1TA300B60
LM1TA350	LM2TA350	350	60	LMM1TA350B60
LM1TA400	LM2TA400	400	70	LMM1TA400B70
LM1TA450	LM2TA450	450	70	LMM1TA450B70
LM1TA500	LM2TA500	500	80	LMM1TA500B80

LIVELLOSTATI ELETTROMAGNETICI SET DA COMPLETARE CON LAMPADA "L"

Electromagnetic level indicators - Set to be completed with signal lamp "L"

Code 3.2.052 - Type LM1BL

Code 3.2.053 - Type LM1BLF

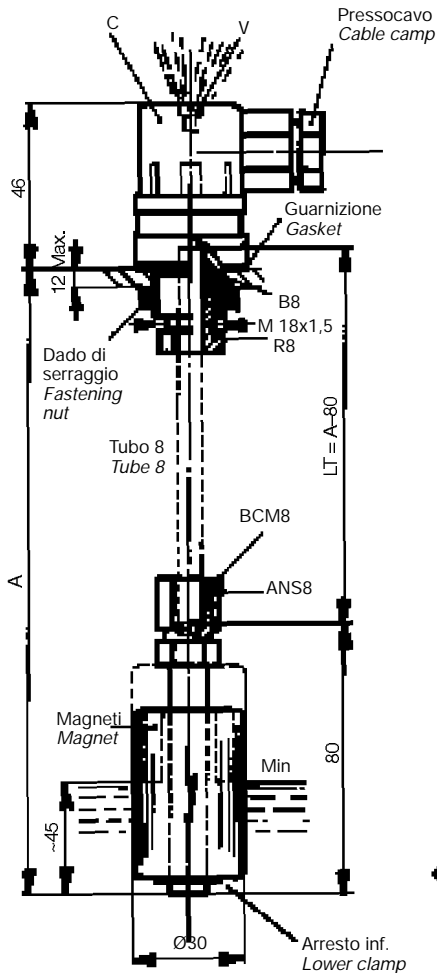

Schema di applicazione
Application chart

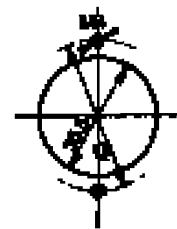
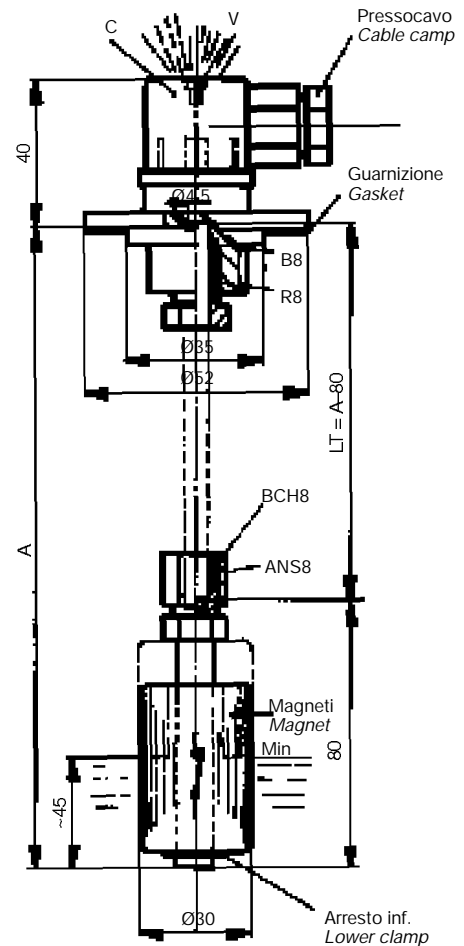
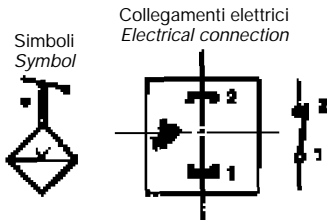
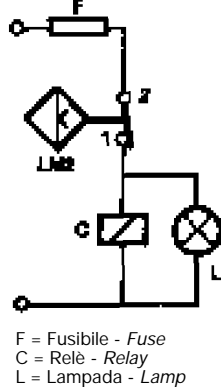

COSTRUZIONE: flangia in alluminio anodizzato, corpo in ottone, molla e anelli di arresto in bronzo, galleggiante in resina espansa NBR.

IMPIEGO E DATI TECNICI (vedere pag. 1 - 2 - 3).

N.B. - Per un corretto funzionamento, serrare con cura i raccordi BCH8 e R8 in modo da ottenere un buon fissaggio e tenuta del tubo di ottone Ø 6 x 8, onde evitare infiltrazioni d'olio nel livellostato e comprometterne il funzionamento. **Nelle ordinazioni indicare la tensione della lampada 24-110-220 V CA.**

MATERIAL: flange in anodized aluminium, fitting cable clamp in brass, B8 bicone and BCH8 union in brass, NBR float.

APPLICATION AND TECHNICAL DATA (see page 1 - 2 - 3).

N.B. - For a correct operation, fasten carefully the BCH8 and the R8 pipe fittings to obtain a firm seal of the Ø 6 x 8 brass pipe and to avoid oil leakage in the level indicator thus affecting its working. **When ordering, indicate the lamp voltage 24-110-220 VAC.**

LIVELLOSTATI ELETTROMAGNETICI CON LAMPADA DI SEGNALAZIONE "L"

Electromagnetic level indicators with signal lamp "L"

Type LM1LA

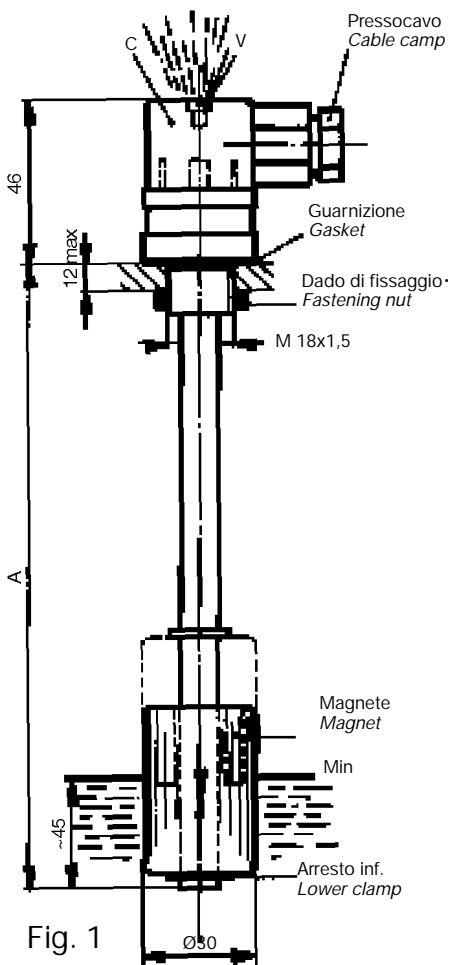

Fig. 1

COSTRUZIONE: flangia filettata in alluminio anodizzato, tubo in ottone, molla e anelli di arresto in bronzo, galleggiante in resina espansa NBR.

IMPIEGO E DATI TECNICI (vedere pag. 1 - 2 -3).

N.B. - A richiesta, forniamo lunghezze superiori, oppure diverse da quelle indicate in tabella. Nelle ordinazioni indicare la tensione della lampada Vca 24-110-220.

Type LM1LFA

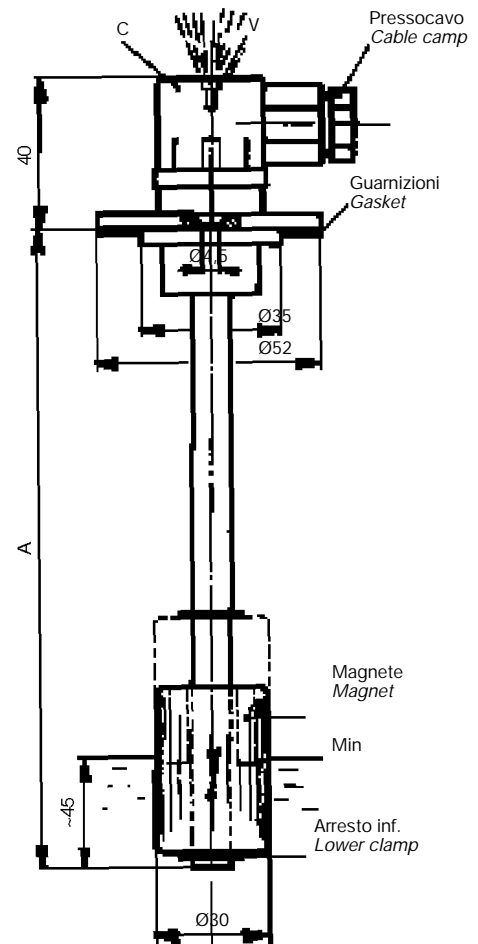
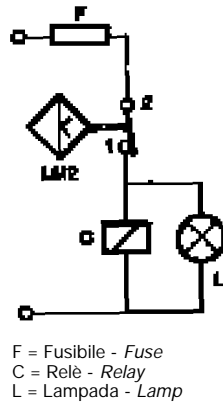
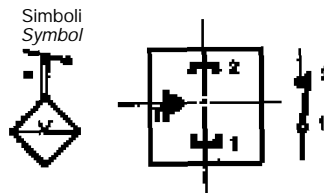

Fig. 2

Schema di applicazione
Application chart



Collegamenti elettrici
Electrical connection



MATERIAL: threaded flange in anodized aluminium, brass tube, spring and stop ring in bronze, NBR expanded resin float.

APPLICATION AND TECHNICAL DATA (see page 1 - 2 -3).

N.B. - On customer's request we supply superior or different lengths from those indicated in the reference table. **When ordering indicate the lamp voltage 24-110-220 Vac.**

FIGURA Picture 1	FIGURA 2 Picture 2	
TIPO Type	A	TIPO Type
LM1LA150	150	LM1LFA150
LM1LA200	200	LM1LFA200
LM1LA250	250	LM1LFA250
LM1LA300	300	LM1LFA300
LM1LA350	350	LM1LFA350
LM1LA400	400	LM1LFA400
LM1LA450	450	LM1LFA450
LM1LA500	500	LM1LFA500

LIVELLOSTATI ELETTROMAGNETICI - MIN. VUOTO

Electromagnetic level indicators - Min.-drain

Type LMV1A...

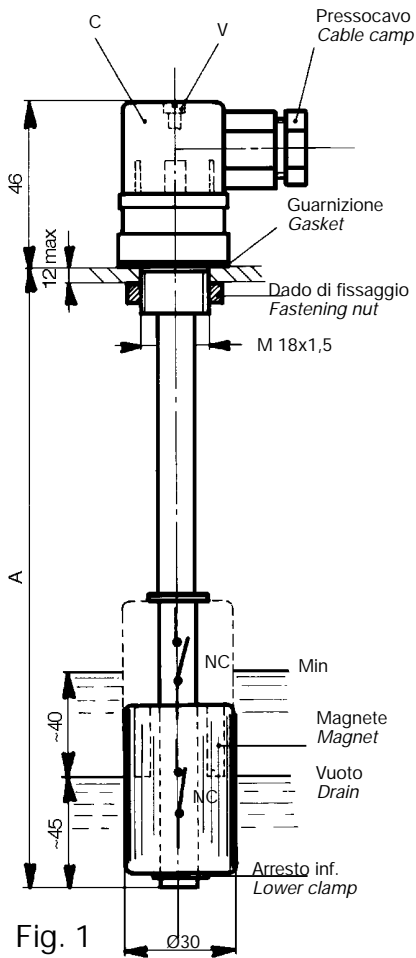

Fig. 1

COSTRUZIONE: flangia filettata in alluminio anodizzato, tubo in ottone, molla e anelli di arresto in bronzo, galleggiante in resina espansa NBR.

IMPIEGO E DATI TECNICI
(vedere pag. 1 - 2 -3).

N.B. - A richiesta, forniamo lunghezze superiori, oppure diverse da quelle indicate in tabella.

Schema di applicazione Application chart

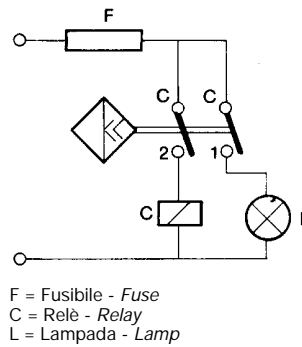

Collegamenti elettrici Electrical connection

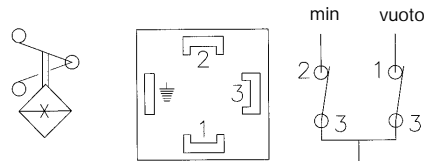

Type LMV1FA...

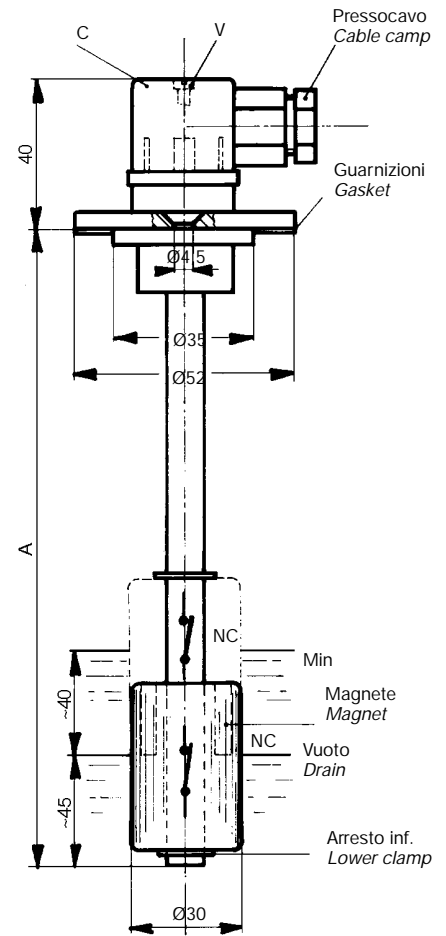

Fig. 2

MATERIAL: threaded flange in anodized aluminium; brass tube; spring and stop ring in bronze; NBR expanded resin float.

APPLICATION AND TECHNICAL DATA
(see page 1 - 2 -3).

N.B. - On customer's request we supply superior or different lengths from those indicated in the reference table.

FIGURA Picture 1	FIGURA Picture 2	
TIPO Type	A	TIPO Type
LMV1A150	150	LMV1FA150
LMV1A200	200	LMV1FA200
LMV1A250	250	LMV1FA250
LMV1A300	300	LMV1FA300
LMV1A350	350	LMV1FA350
LMV1A400	400	LMV1FA400
LMV1A450	450	LMV1FA450
LMV1A500	500	LMV1FA500

LIVELLOSTATI ELETTROMAGNETICI

Electromagnetic level indicators

Type LMA1FA...
LMA2FA...

Type LMMA1FA

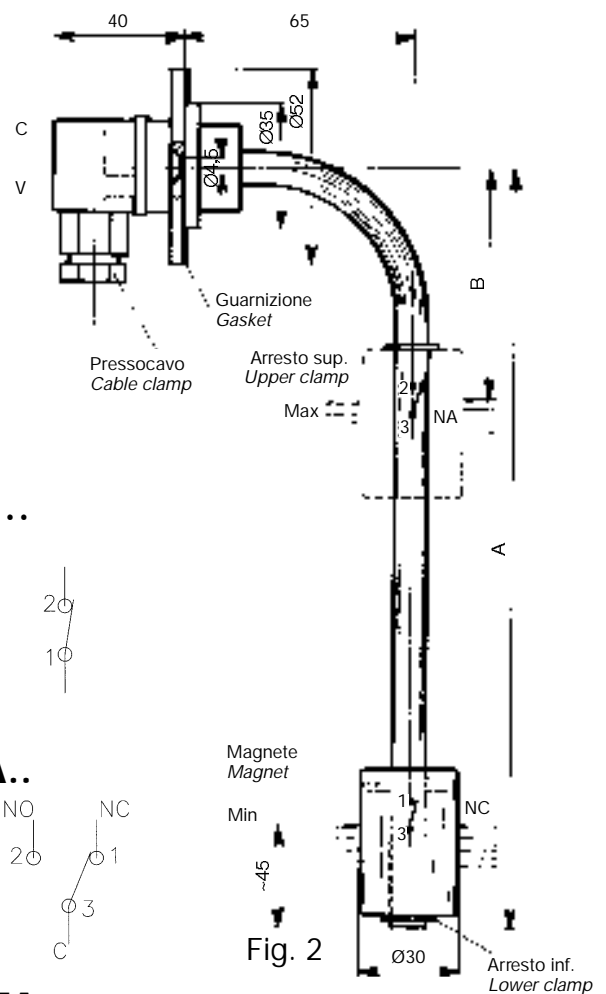
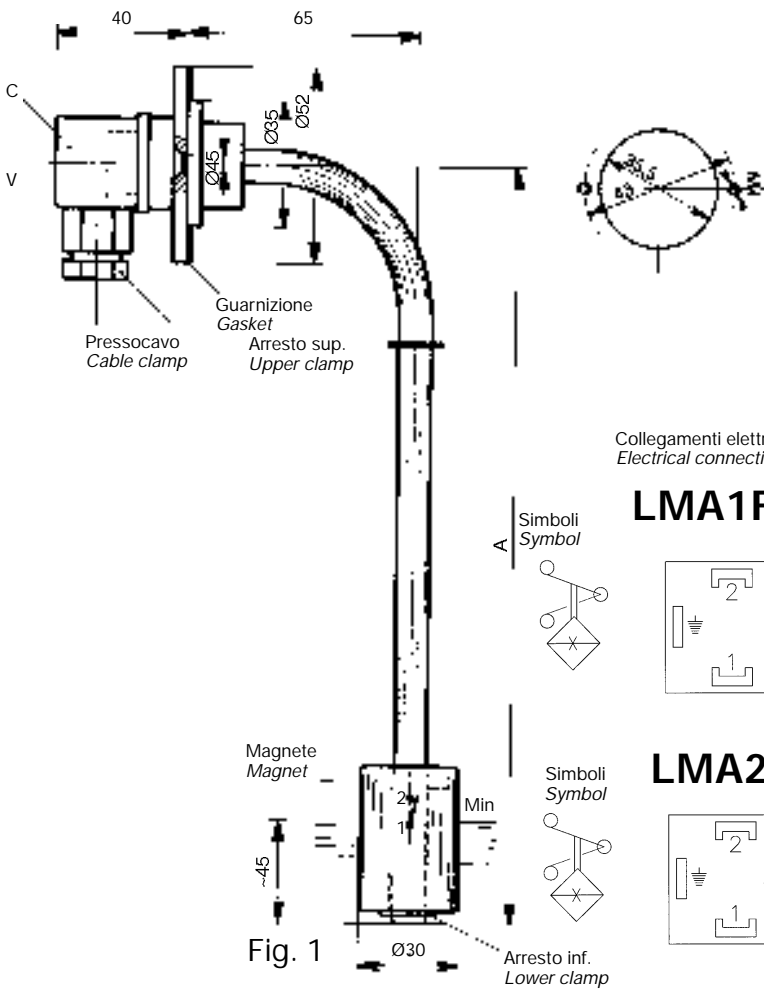

COSTRUZIONE: flangia in alluminio anodizzato, tubo in ottone, molla e anelli di arresto in bronzo, galleggiante in resina espansa NBR.

IMPIEGO E DATI TECNICI (vedere pag. 1 - 2 - 3).

N.B. - A richiesta, forniamo lunghezze superiori, oppure diverse da quelle indicate in tabella.

MATERIAL: flange in anodized aluminium, brass tube, spring and stop ring in bronze, NBR expanded resin float.

APPLICATION AND TECHNICAL DATA (see page 1 - 2 - 3).

N.B. - On customer's request we supply superior or different lengths from those indicated in the reference table.

FIGURA 1 Picture 1		FIGURA 2 Picture 2		
		A	B	
TIPO Type	TIPO Type			TIPO Type
LMA1FA150	LMA2FA150	150	60	LMMA1FA150B60
LMA1FA200	LMA2FA200	200	70	LMMA1FA200B70
LMA1FA250	LMA2FA250	250	70	LMMA1FA250B70
LMA1FA300	LMA2FA300	300	70	LMMA1FA300B70
LMA1FA350	LMA2FA350	350	70	LMMA1FA350B70
LMA1FA400	LMA2FA400	400	70	LMMA1FA400B70
LMA1FA450	LMA2FA450	450	80	LMMA1FA450B80
LMA1FA500	LMA2FA500	500	80	LMMA1FA500B80

LIVELLOSTATI ELETTROMAGNETICI

Electromagnetic level indicators

Type **LM1CS...**
LM2CS...

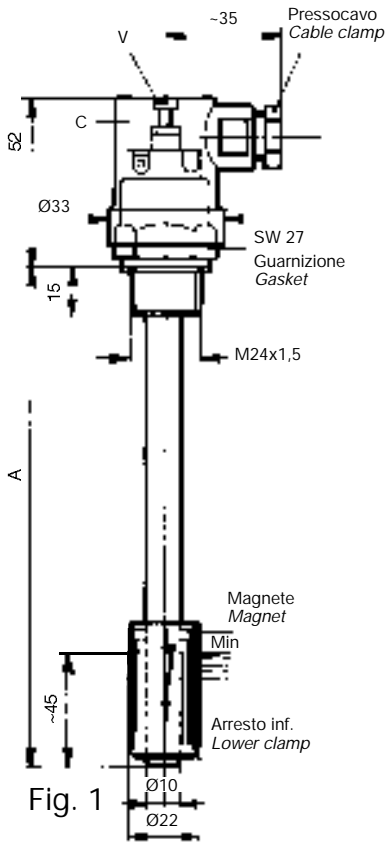

COSTRUZIONE: corpo ottone nichelato, tubo in ottone, molla e anelli di arresto in bronzo, galleggianti in resina espansa NBR.

IMPIEGO E DATI TECNICI
(vedere pag. 1 - 2 -3).

N.B. - A richiesta, forniamo lunghezze superiori, oppure diverse da quelle indicate in tabella.

Schema di applicazione
Application chart

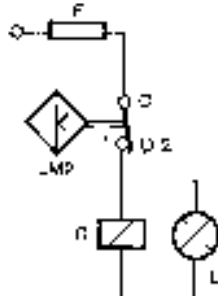

F = Fusibile - Fuse
C = Relè - Relay
L = Lampada - Lamp

Collegamenti elettrici
Electrical connection

LM1CSA

Simboli
Symbol

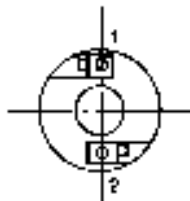

LM2CS...

Simboli
Symbol

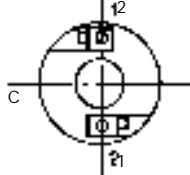

LMM1CSA...

Simboli
Symbol

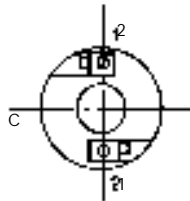

Type **LMM1CS...**

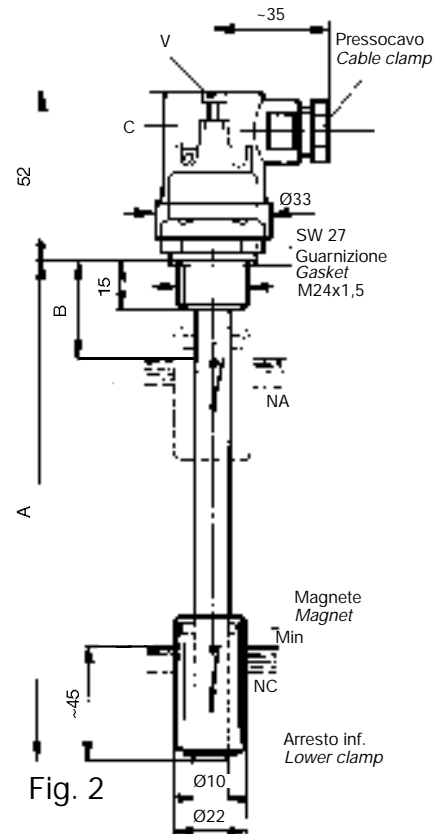

MATERIAL: body in nickel-plated brass, brass tube, spring and stop ring in bronze, NBR expanded resin float.

APPLICATION AND TECHNICAL DATA
(see page 1 - 2 -3).

N.B. - On customer's request we supply superior or different lengths from those indicated in the reference table.

FIGURA 1 Picture 1		FIGURA 2 Picture 2		
		A	B	
TIPO Type	TIPO Type			TIPO Type
LM1CSA150	LM2CSA150	150	40	LMM1CSA150B40
LM1CSA200	LM2CSA200	200	60	LMM1CSA200B60
LM1CSA250	LM2CSA250	250	60	LMM1CSA250B60
LM1CSA300	LM2CSA300	300	60	LMM1CSA300B60
LM1CSA350	LM2CSA350	350	60	LMM1CSA350B60
LM1CSA400	LM2CSA400	400	70	LMM1CSA400B70
LM1CSA450	LM2CSA450	450	70	LMM1CSA450B70
LM1CSA500	LM2CSA500	500	80	LMM1CSA500B80

LIVELLOSTATI ELETTROMAGNETICI

Electromagnetic level indicators

Type LM1CA...
LM2CA...

Type LMM1CA...

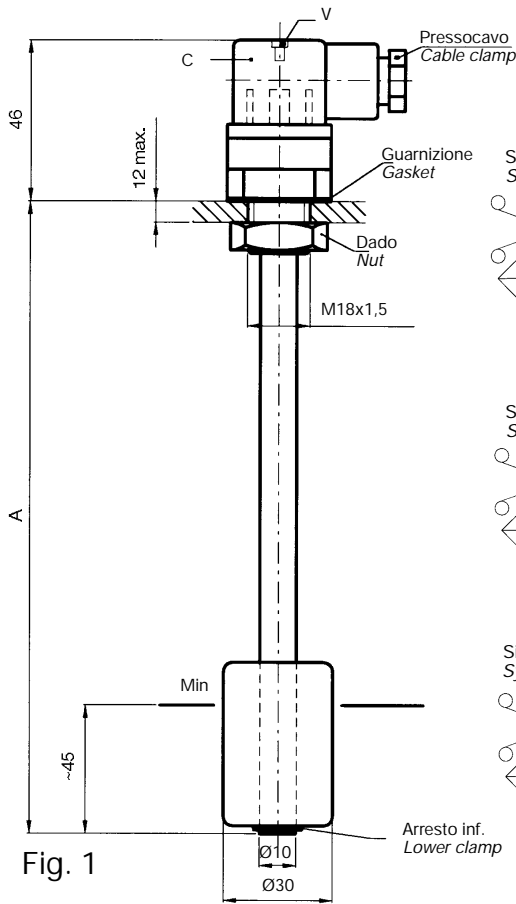
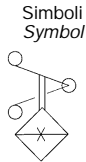
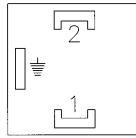

Fig. 1

Collegamenti elettrici
Electrical connection

LM1



LM2

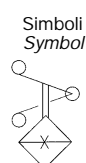
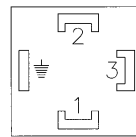

LMM1

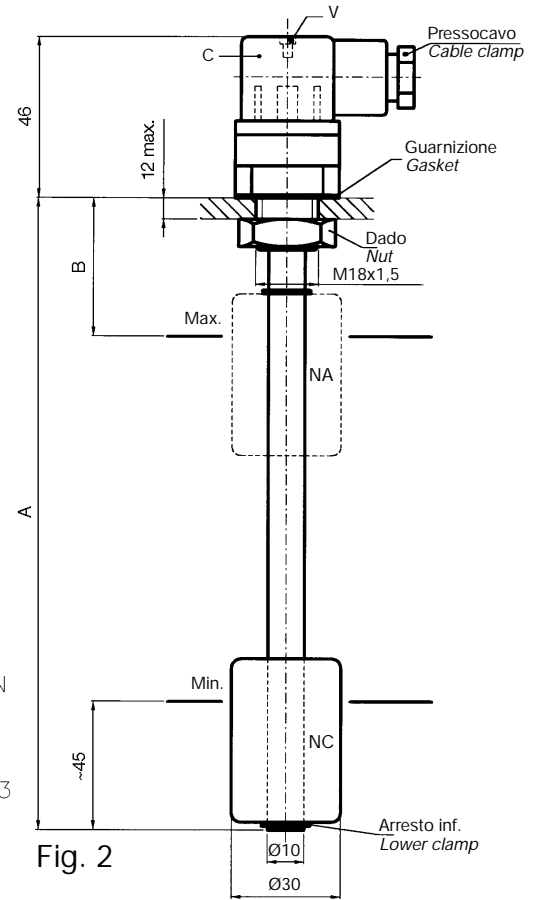
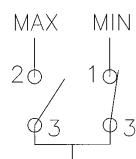
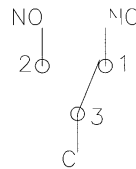
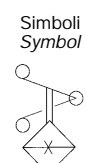
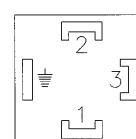

Fig. 2

COSTRUZIONE: corpo filettato in alluminio anodizzato, tubo in ottone, molla e anelli di arresto in bronzo, galleggiante in resina espansa NBR.

MATERIAL: threaded body in anodized aluminium, brass tube; spring and stop ring in bronze, NBR expanded resin float.

IMPIEGO E DATI TECNICI
(vedere pag. 1 - 2 -3).

APPLICATION AND TECHNICAL DATA
(see page 1 - 2 -3).

N.B. - A richiesta, forniamo lunghezze superiori, oppure diverse da quelle indicate in tabella.

N.B. - On customer's request we supply superior or different lengths from those indicated in the reference table.

FIGURA 1 Picture 1		FIGURA 2 Picture 2		
		A	B	
TIPO Type	TIPO Type			TIPO Type
LM1CA100	LM2CA100	100		
LM1CA150	LM2CA150	150	40	LMM1CA150B40
LM1CA200	LM2CA200	200	60	LMM1CA200B60
LM1CA250	LM2CA250	250	60	LMM1CA250B60
LM1CA300	LM2CA300	300	60	LMM1CA300B60
LM1CA350	LM2CA350	350	60	LMM1CA350B60
LM1CA400	LM2CA400	400	70	LMM1CA400B70
LM1CA450	LM2CA450	450	70	LMM1CA450B70
LM1CA500	LM2CA500	500	80	LMM1CA500B80

LIVELLO STATI ELETTROMAGNETICI

Electromagnetic level indicators

Type LM1CFA...
LM2CFA...

Type LMM1CFA...

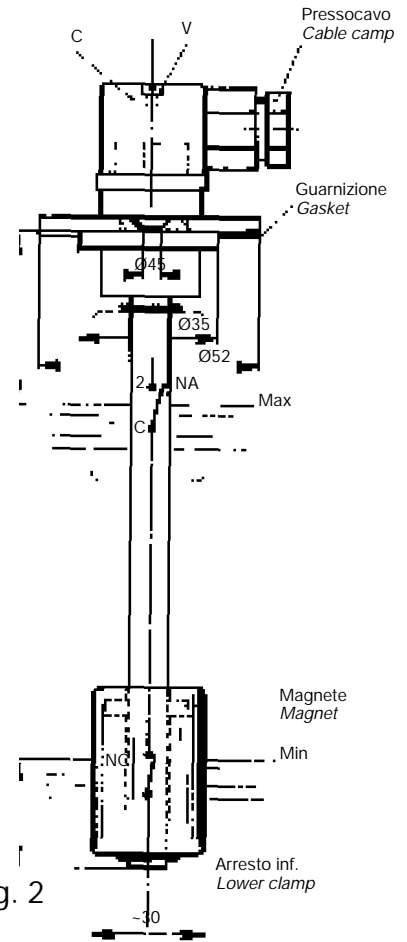
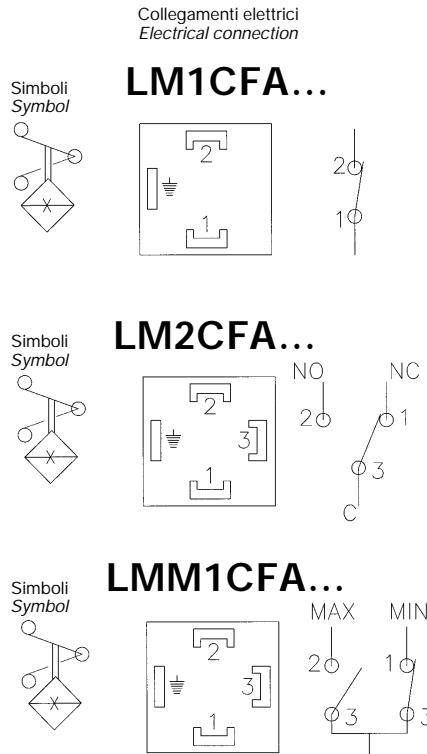
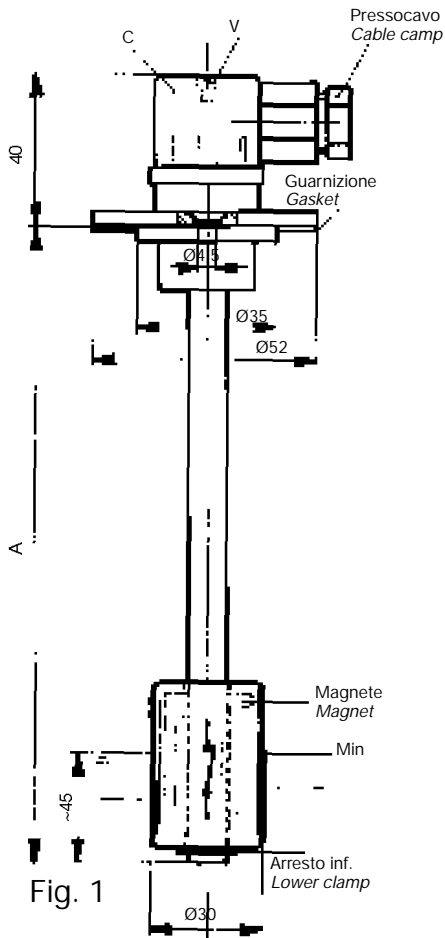

COSTRUZIONE: flangia in alluminio anodizzato, tubo in ottone, molla e anelli di arresto in bronzo, galleggiante in resina espansa NBR.

IMPIEGO E DATI TECNICI
(vedere pag. 1 - 2 -3).

N.B. - A richiesta, forniamo lunghezze superiori, oppure diverse da quelle indicate in tabella.

MATERIAL: flange in anodized aluminium, brass tube, spring and stop ring in bronze, NBR expanded resin float.

APPLICATION AND TECHNICAL DATA
(see page 1 - 2 -3).

N.B. - On customer's request we supply superior or different lengths from those indicated in the reference table.

FIGURA 1 Picture 1		FIGURA 2 Picture 2		
		A	B	
TIPO Type	TIPO Type			TIPO Type
LM1CFA150	LM2CFA150	150	40	LMM1CFA150B40
LM1CFA200	LM2CFA200	200	60	LMM1CFA200B60
LM1CFA250	LM2CFA250	250	60	LMM1CFA250B60
LM1CFA300	LM2CFA300	300	60	LMM1CFA300B60
LM1CFA350	LM2CFA350	350	60	LMM1CFA350B60
LM1CFA400	LM2CFA400	400	70	LMM1CFA400B70
LM1CFA450	LM2CFA450	450	70	LMM1CFA450B70
LM1CFA500	LM2CFA500	500	80	LMM1CFA500B80

LIVELLOSTATI ELETTROMAGNETICI SET DA COMPLETARE

Electromagnetic level indicators - Set to be completed

Type LM1BFP...
LM2BFP...

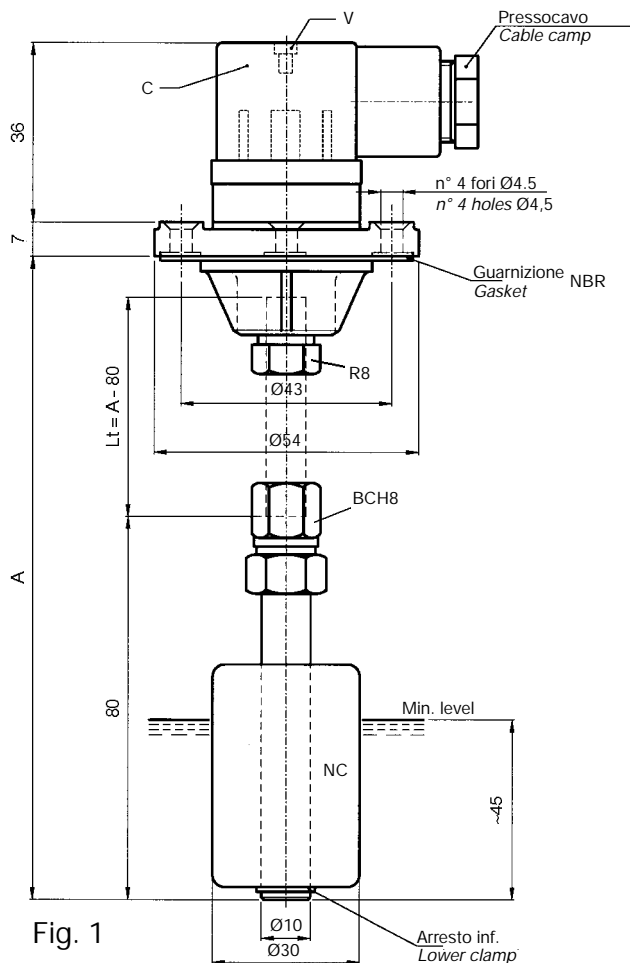
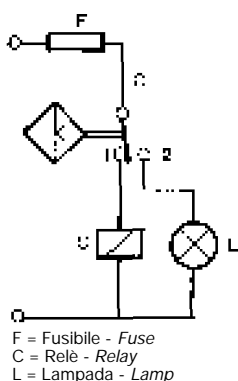

Fig. 1

Type LM1BTP...
LM2BTP...

Schema di applicazione
Application chart



Collegamenti elettrici
Electrical connection

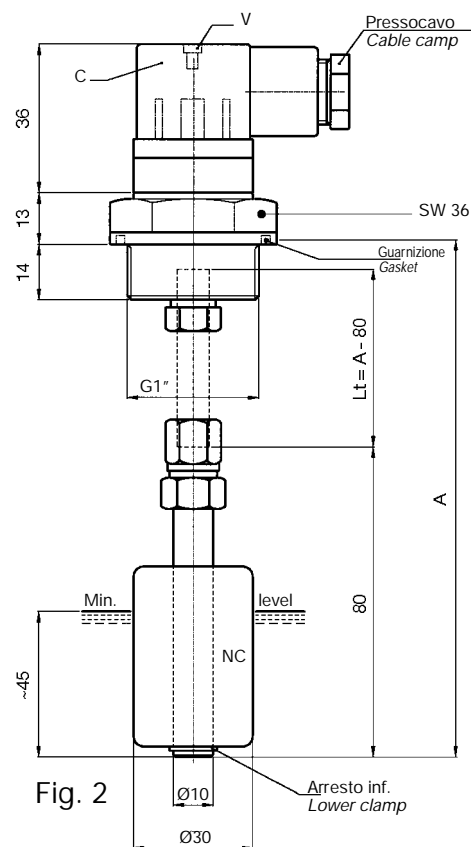
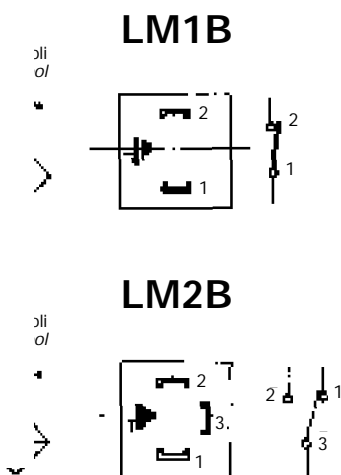

Fig. 2

COSTRUZIONE: flangia in termoplastico, asta in ottone, molla e anelli di arresto in bronzo, galleggiante in resina espansa NBR.

IMPIEGO E DATI TECNICI (vedere pag. 1 - 2 -3).

N.B. - Per un corretto funzionamento, serrare con cura i raccordi BCH8 e R8 in modo da ottenere un buon fissaggio e tenuta del tubo di ottone Ø 6 x 8, onde evitare infiltrazioni d'olio nel livellostato e comprometterne il funzionamento.

MATERIAL: flange in thermoplastic, brass stem, fitting cable clamp in brass, B8 bicone and BCH8 union in brass, NBR float.

APPLICATION AND TECHNICAL DATA (see page 1 - 2 -3).

N.B. - For a correct operation, fasten carefully the BCH8 and the R8 pipe fittings to obtain a firm seal of the Ø 6 x 8 brass pipe and to avoid oil leakage in the level indicator thus affecting its working.

LIVELLOSTATI ELETTROMAGNETICI

Electromagnetic level indicators

Type LM1CFPA...
LM2CFPA...

Type LMM1CFPA... B...

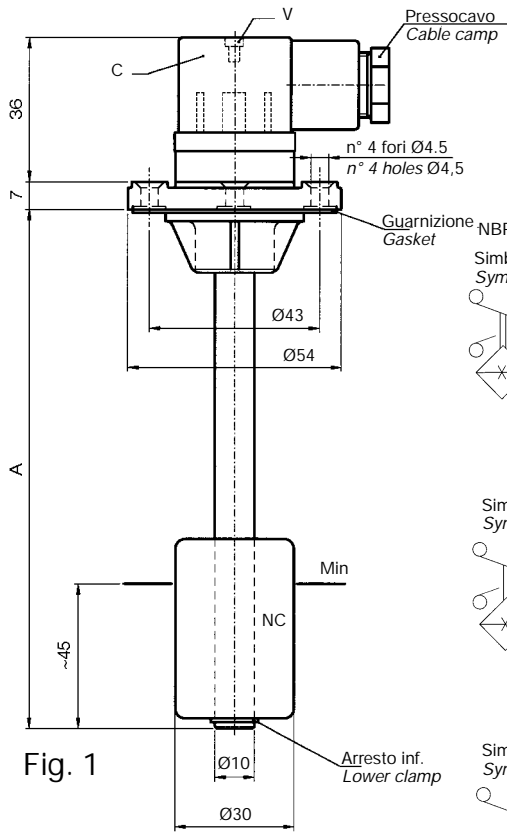
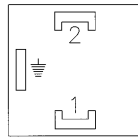
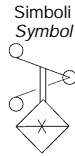

Fig. 1

Collegamenti elettrici
Electrical connection

LM1CFPA...



LM2CFPA

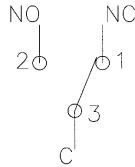
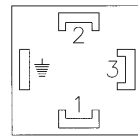
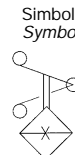

LMM1CFPA...

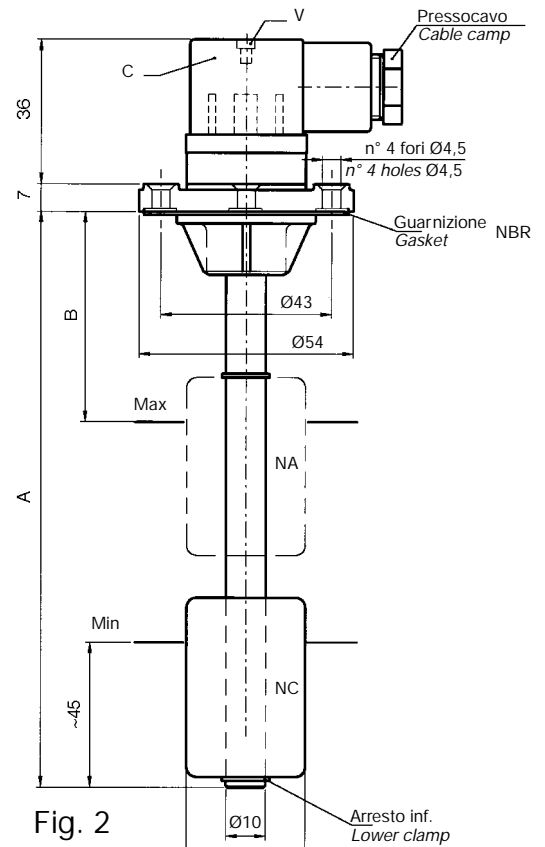
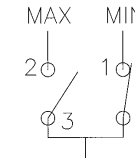
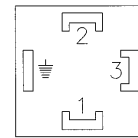
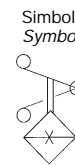

Fig. 2

COSTRUZIONE: flangia in termoplastico, tubo in ottone, molla e anelli di arresto in bronzo, galleggiante in resina espansa NBR.

IMPIEGO E DATI TECNICI
(vedere pag. 1 - 2 - 3).

N.B. - A richiesta, forniamo lunghezze superiori, oppure diverse da quelle indicate in tabella.

MATERIAL: flange in thermoplastic, brass tube, spring and stop ring in bronze, NBR expanded resin float.

APPLICATION AND TECHNICAL DATA
(see page 1 - 2 - 3).

N.B. - On customer's request we supply superior or different lengths from those indicated in the reference table.

FIGURA 1 Picture 1		FIGURA 2 Picture 2		
		A	B	
TIPO Type	TIPO Type			TIPO Type
LM1CFPA150	LM2CFPA150	150	40	LMM1CFPA150B40
LM1CFPA200	LM2CFPA200	200	60	LMM1CFPA200B60
LM1CFPA250	LM2CFPA250	250	60	LMM1CFPA250B60
LM1CFPA300	LM2CFPA300	300	60	LMM1CFPA300B60
LM1CFPA350	LM2CFPA350	350	60	LMM1CFPA350B60
LM1CFPA400	LM2CFPA400	400	70	LMM1CFPA400B70
LM1CFPA450	LM2CFPA450	450	70	LMM1CFPA450B70
LM1CFPA500	LM2CFPA500	500	80	LMM1CFPA500B80

LIVELLOSTATI ELETTROMAGNETICI

Electromagnetic level indicators

Type LM1CTP...
LM2CTP...

Type LMM1CTP

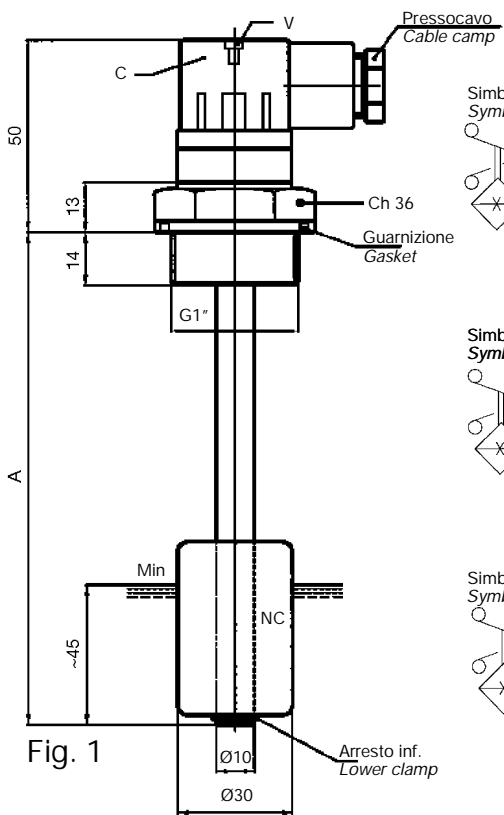

Collegamenti elettrici
Electrical connection

LM1CTPA...

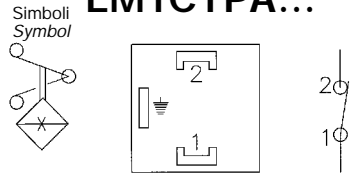

LM2CTPA

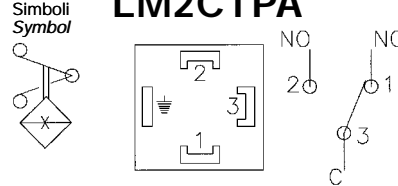

LMM1CTPA...

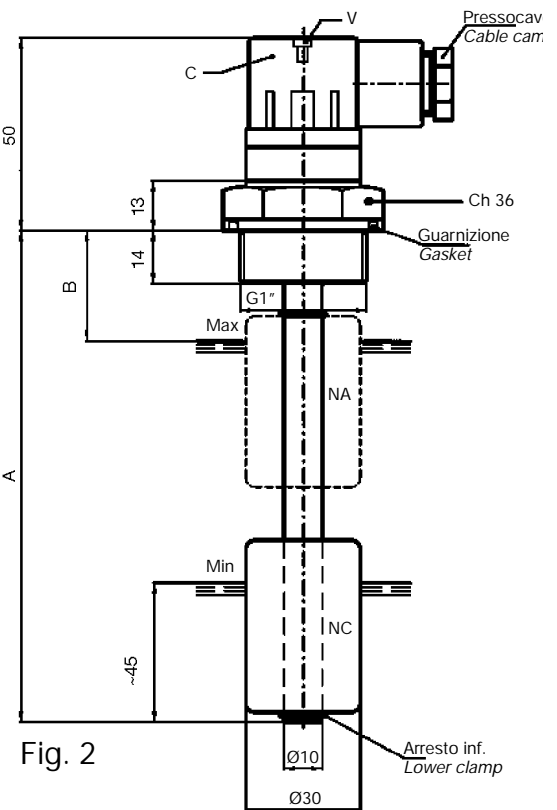
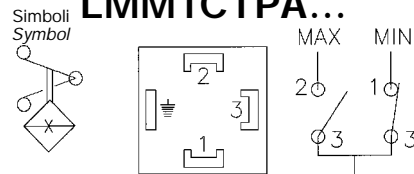

COSTRUZIONE: flangia filettata in termoplastico, tubo in ottone, molla e anelli di arresto in bronzo, galleggiante in resina espansa NBR.

IMPIEGO E DATI TECNICI
(vedere pag. 1 - 2 - 3).

N.B. - A richiesta, forniamo lunghezze superiori, oppure diverse da quelle indicate in tabella.

MATERIAL: threaded flange in thermoplastic, brass tube, spring and stop ring in bronze, NBR expanded resin float.

APPLICATION AND TECHNICAL DATA
(see page 1 - 2 - 3).

N.B. - On customer's request we supply superior or different lengths from those indicated in the reference table.

FIGURA 1 Picture 1		FIGURA 2 Picture 2		
		A	B	
TIPO Type	TIPO Type			TIPO Type
LM1CTPA150	LM2CTPA150	150	40	LMM1CTPA150B40
LM1CTPA200	LM2CTPA200	200	60	LMM1CTPA200B60
LM1CTPA250	LM2CTPA250	250	60	LMM1CTPA250B60
LM1CTPA300	LM2CTPA300	300	60	LMM1CTPA300B60
LM1CTPA350	LM2CTPA350	350	60	LMM1CTPA350B60
LM1CTPA400	LM2CTPA400	400	70	LMM1CTPA400B70
LM1CTPA450	LM2CTPA450	450	70	LMM1CTPA450B70
LM1CTPA500	LM2CTPA500	500	80	LMM1CTPA500B80

LIVELLOSTATI ELETTROMAGNETICI

Electromagnetic level indicators

Code 3.2.360 - Type LM1TB
Code 3.2.370 - Type LM2TB

CON LAMPADA "L"
with signal lamp "L"
Code 3.2.380 - Type LM1TBL

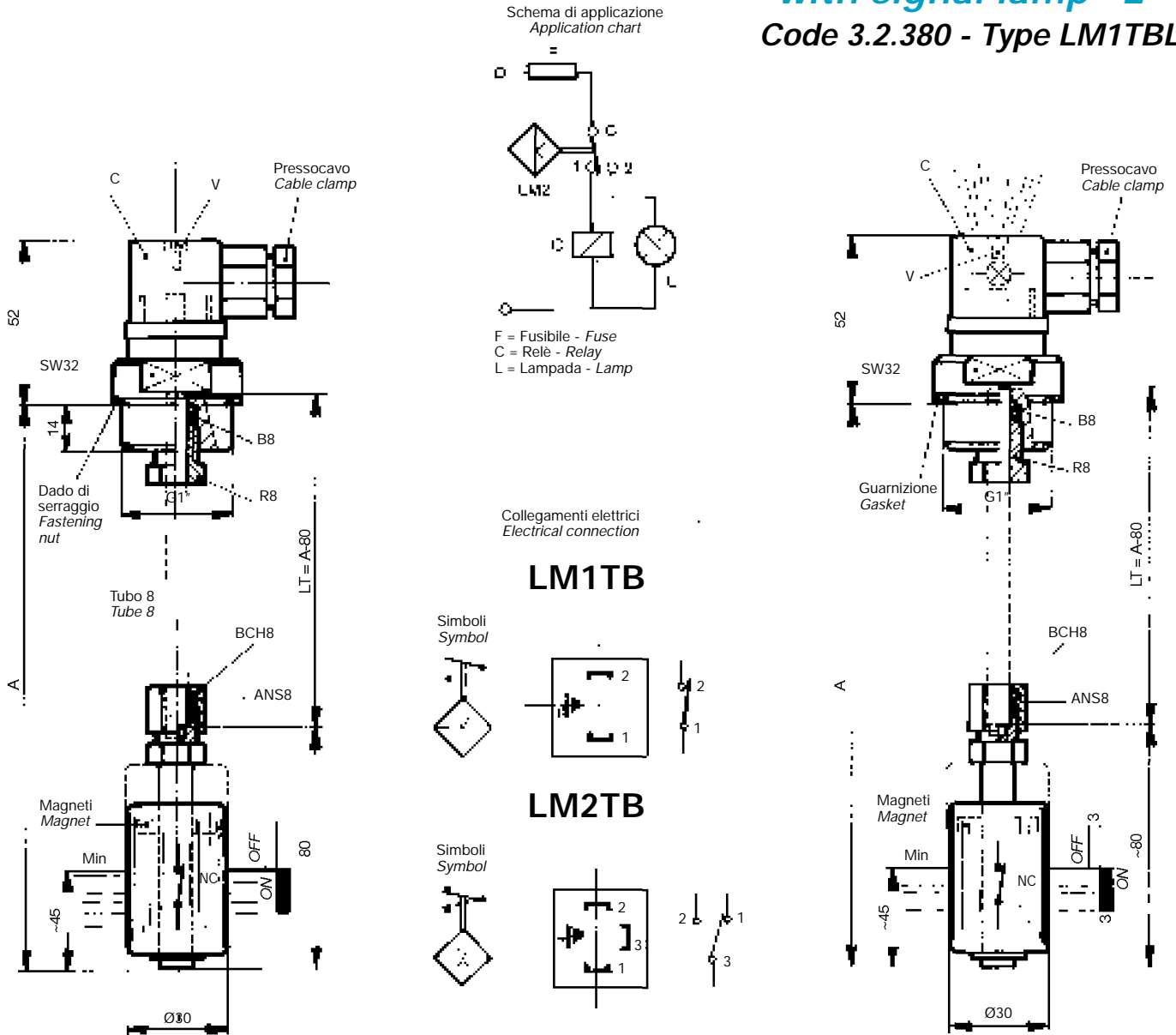

COSTRUZIONE: flangia filettata G1" in alluminio anodizzato, raccordo R8 in ottone nichelato, bicono B8, bocchettone in ottone BCH8, anello di serraggio ANS8; tubo di ottone; galleggiante NBR..

IMPIEGO E DATI TECNICI (vedere pag. 1 - 2 -3).

N.B. - Per un corretto funzionamento, serrare con cura i due raccordi BCH8 e R8, in modo da ottenere un buon fissaggio e tenuta del tubo di ottone Ø6x8, onde evitare infiltrazioni d'olio nel livellostato e comprometterne il funzionamento. **Nelle ordinazioni indicare la tensione della lampada Vca 24-110-220.**

MATERIAL: G1" threaded flange in anodized aluminium; R8 fitting in nickel-plated brass; B8 bicone and BCH8 union in brass; ANS8 fastening ring; brass tube; NBR float.

APPLICATION AND TECHNICAL DATA (see page 1 - 2 -3).

N.B. - For a correct operation, fasten carefully the BCH8 and the R8 pipe fittings to obtain a firm seal of the Ø6x8 brass pipe and to avoid oil leakage in the level indicator thus affecting its working. **When ordering indicate the lamp voltage 24-110-220 Vac.**

LIVELLOSTATI ELETTROMAGNETICI

Electromagnetic level indicators

Type LM1CTA...
LM2CTA...

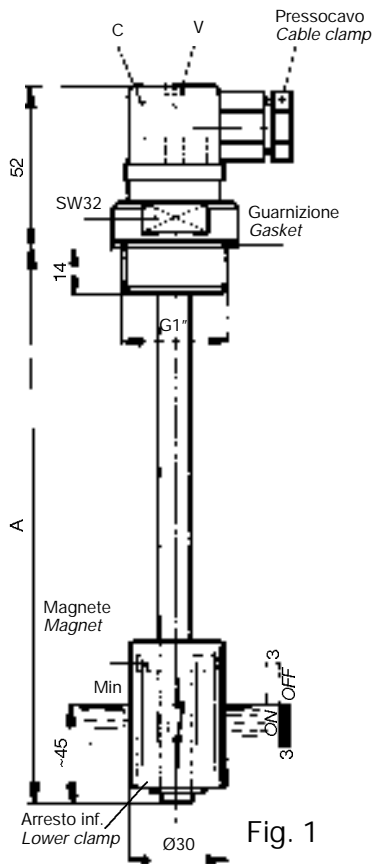
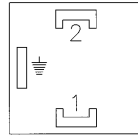
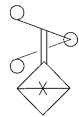

Fig. 1

Collegamenti elettrici
Electrical connection

LM1CTA...

Simboli
Symbol



LM2CTA...

Simboli
Symbol

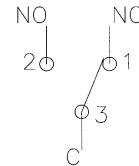
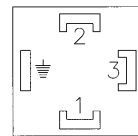
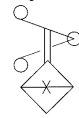

LMM1CTA...

Simboli
Symbol

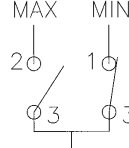
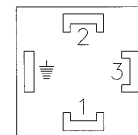
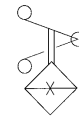

Type LMM1CTA...

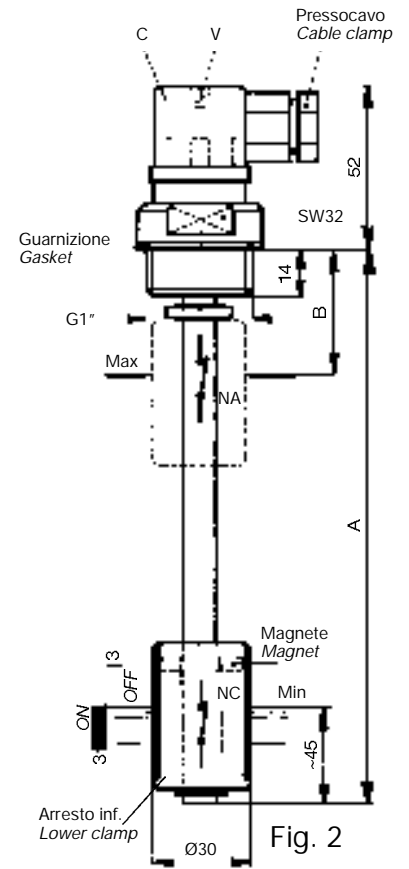

Fig. 2

COSTRUZIONE: flangia filettata in alluminio anodizzato, tubo in ottone, molla e anelli di arresto in bronzo, galleggiante in resina espansa NBR.

IMPIEGO E DATI TECNICI (vedere pag. 1 - 2 -3).

N.B. - A richiesta, forniamo lunghezze superiori, oppure diverse da quelle indicate in tabella.

MATERIAL: threaded flange in anodized aluminium; brass tube; spring and stop ring in bronze, NBR expended resin float.

APPLICATION AND TECHNICAL DATA (see page 1 - 2 -3).

N.B. - On customer's request we supply superior or different lengths from those indicated in the reference table.

FIGURA 1 Picture 1		FIGURA 2 Picture 2		
		A	B	
TIPO Type	TIPO Type			TIPO Type
LM1CTA150	LM2CTA150	150	40	LMM1CTA150B40
LM1CTA200	LM2CTA200	200	60	LMM1CTA200B60
LM1CTA250	LM2CTA250	250	60	LMM1CTA250B60
LM1CTA300	LM2CTA300	300	60	LMM1CTA300B60
LM1CTA350	LM2CTA350	350	60	LMM1CTA350B60
LM1CTA400	LM2CTA400	400	70	LMM1CTA400B70
LM1CTA450	LM2CTA450	450	70	LMM1CTA450B70
LM1CTA500	LM2CTA500	500	80	LMM1CTA500B80

LIVELLOSTATI ELETTROMAGNETICI - CON TERMOSTATO FISSO

Electromagnetic level indicators - With fixed thermostat

Type LM1A... T...

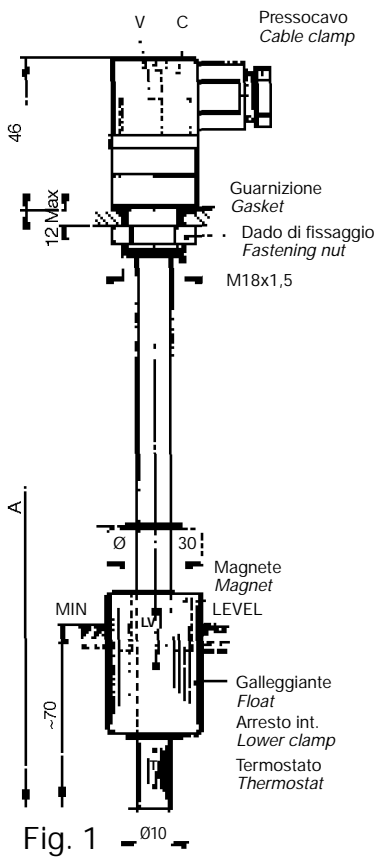

Schema di applicazione
Application chart

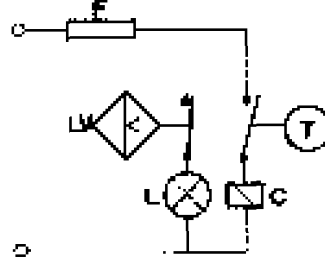

F = Fusibile - Fuse
C = Relè - Relay
L = Lampada - Lamp

Collegamenti elettrici
Electrical connection

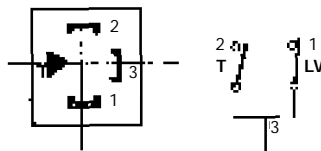

Type LM1FA... T...

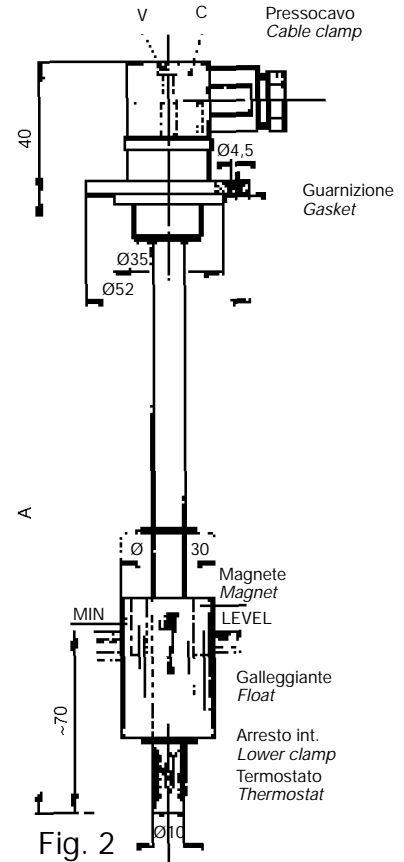

Esempio di ordinazione: LM1A200T50 (50°C) - Fig. 1
Example of order:



COSTRUZIONE: flangia in alluminio anodizzato, tubo in ottone, molla e anelli di arresto in bronzo, galleggiante in resina espansa NBR, termostato bimetallico fisso con contatto NA (V 220/50 Hz - 0,5 A resistivi), differenziale T = 5°C.

Sono disponibili le seguenti temperature: 40° - 50° - 60° - 70° - 80°C.

IMPIEGO E DATI TECNICI (vedere pag. 1 - 2 - 3).

N.B. - A richiesta, forniamo lunghezza superiori, oppure diverse da quelle indicate in tabella.

MATERIAL: flange in anodized aluminium, brass tube, spring and stop ring in bronze, NBR expanded resin float, bimetallic fixed thermostat with NO contact (V 220/50 Hz - 0,5 A resistive), differential T = 5°C.

Following temperatures are possible: 40° - 50° - 60° - 70° - 80°C.

APPLICATION AND TECHNICAL DATA (see page 1 - 2 - 3).

N.B. - On customer's request we supply superior or different lengths from those indicated in the reference table.

Type Fig. 1	Type Fig. 2	Lungh. A	Temperature range Temperatura °C
LM1A150T...	LM1FA150T...	150	40 50 60 70 80
LM1A200T...	LM1FA200T...	200	
LM1A250T...	LM1FA250T...	250	
LM1A300T...	LM1FA300T...	300	
LM1A350T...	LM1FA350T...	350	
LM1A400T...	LM1FA400T...	400	
LM1A450T...	LM1FA450T...	450	
LM1A500T...	LM1FA500T...	500	

LIVELLOSTATI ELETTROMAGNETICI - CON TERMOSTATO FISSO

Electromagnetic level indicators - With fixed thermostat

Type LM1TA... T...

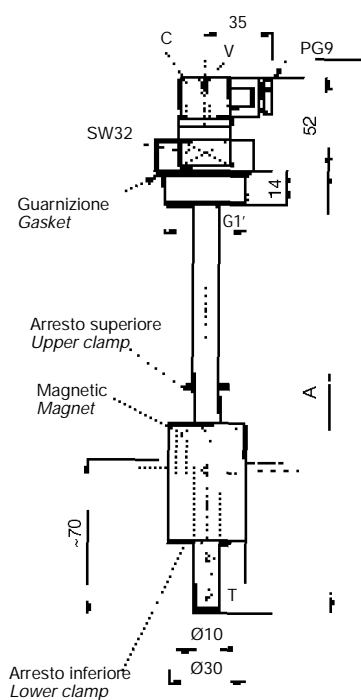

Collegamenti elettrici
Electrical connection

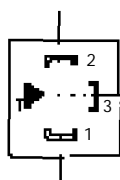

Schema di applicazione
Application chart

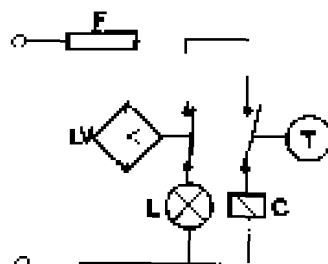

F = Fusibile - Fuse
C = Relè - Relay
L = Lampada - Lamp

Esempio di ordinazione: LM1TA300T60 (60°C)
Example of order:

Lunghezze standard 150 - 200 - 250 - 300 - 350 - 400 - 450 - 500
Standard lengths

COSTRUZIONE: flangia filettata in alluminio anodizzato, tubo in ottone, molla e anelli di arresto in bronzo, galleggiante in resina espansa NBR, termostato bimetallico fisso con contatto NA (V 220/50 Hz - 0,5 A resistivi), differenziale T = 5°C.

Sono disponibili le seguenti temperature: 40° - 50° - 60° - 70° - 80°C.

IMPIEGO E DATI TECNICI (vedere pag. 1 - 2 -3).

N.B. - A richiesta, forniamo lunghezze superiori, oppure diverse da quelle indicate in tabella.

MATERIAL: threaded flange in anodized aluminium, brass tube, spring and stop ring in bronze, NBR expanded resin float, bimetallic fixed thermostat with NO contact (V 220/50 Hz - 0,5 A resistive), differential T = 5°C.

The following temperatures are possible: 40° - 50° - 60° - 70° - 80°C.

APPLICATION AND TECHNICAL DATA (see page 1 - 2 -3).

N.B. - On customer's request we supply superior or different lengths from those indicated in the reference table.

LIVELLOSTATI ELETTROMAGNETICI - SET DA COMPLETARE CON TERMOSTATO FISSO

Electromagnetic level indicators - set to be completed With fixed thermostat

Code 3.2.970 - Type LM1FT...

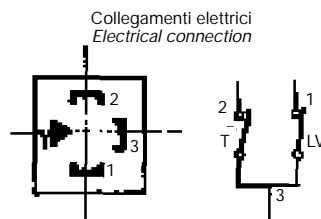
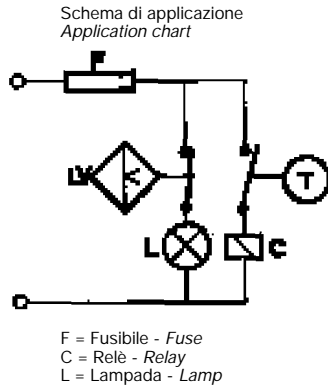
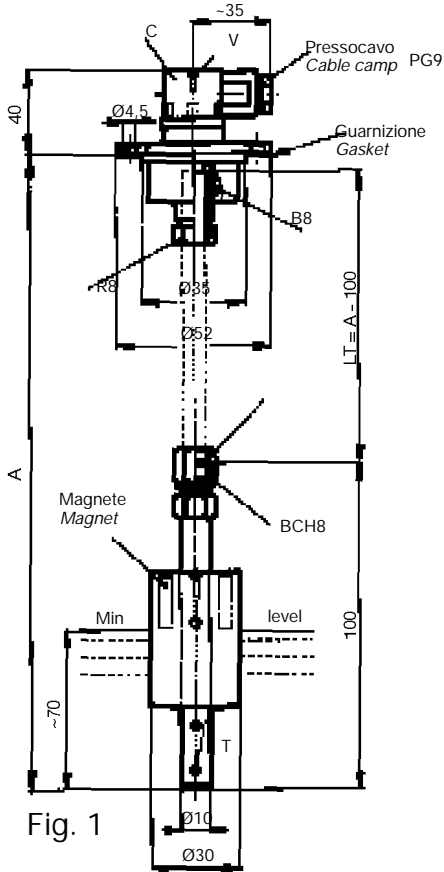

Esempio di ordinazione: LM1FT50 (50°C)
Example of order:



Code 3.2.975 - Type LM1T...

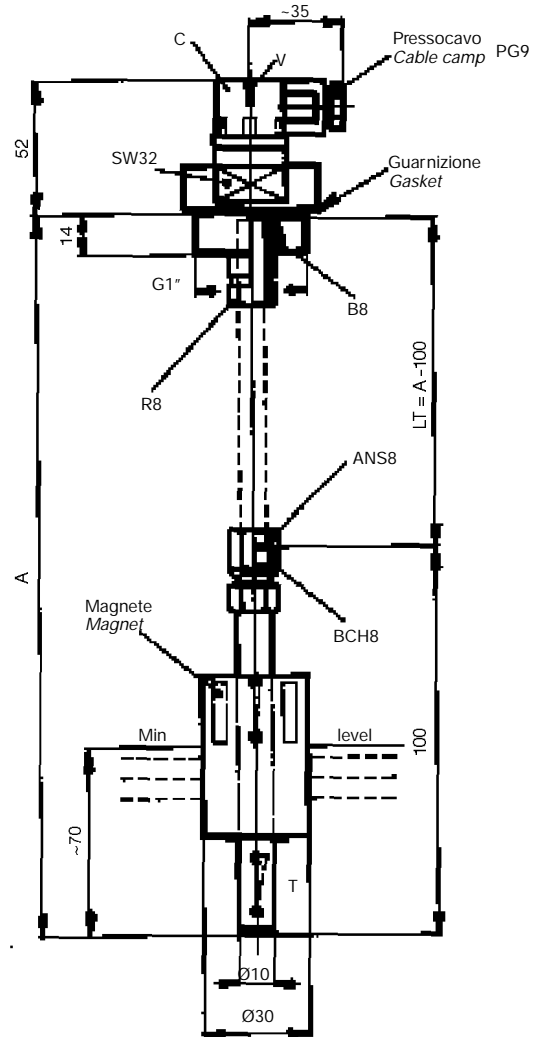

Sono disponibili le seguenti temperature:
40° - 50° - 60° - 70° - 80°C.

COSTRUZIONE: flangia in alluminio anodizzato, tubo in ottone, molla e anelli di ar resto in bronzo, galleggiante in resina espansa NBR, termostato bimetallico fisso con contatto NA (V 220/50 Hz - 0,5 A resistivi), differenziale T = 5°C.

IMPIEGO E DATI TECNICI (vedere pag. 1 - 2 -3).

N.B. - Per un corretto funzionamento, serrare con cura i raccordi BCH8 e R8 in modo da ottenere un buon fissaggio e tenuta del tubo di ottone Ø 6 x 8, onde evitare infiltrazioni d'olio nel livellostato e comprometterne il funzionamento.

Following temperatures are possible:
40° - 50° - 60° - 70° - 80°C.

MATERIAL: threaded flange in anodized aluminium, brass tube, spring and stop ring in bronze, NBR expanded resin float, bimetallic fixed thermostat with NO contact (V 220/50 Hz - 0,5 A resistiv), differential T = 5°C.

APPLICATION AND TECHNICAL DATA (see page 1 - 2 -3).

N.B. - For a correct operation, fasten carefully the BCH8 and the R8 pipe fittings to obtain a firm seal of the Ø 6 x 8 brass pipe and to avoid oil leakage in the level indicator thus affecting its working.

LIVELLOSTATI ELETTROMAGNETICI - INOX

SET DA COMPLETARE

Electromagnetic level indicators - Stainless steel

Set to be completed

Code 3.2.160 - Type LM1PI
Code 3.2.170 - Type LM2PI

Code 3.2.180 - Type LM1BFI
Code 3.2.190 - Type LM2BFI

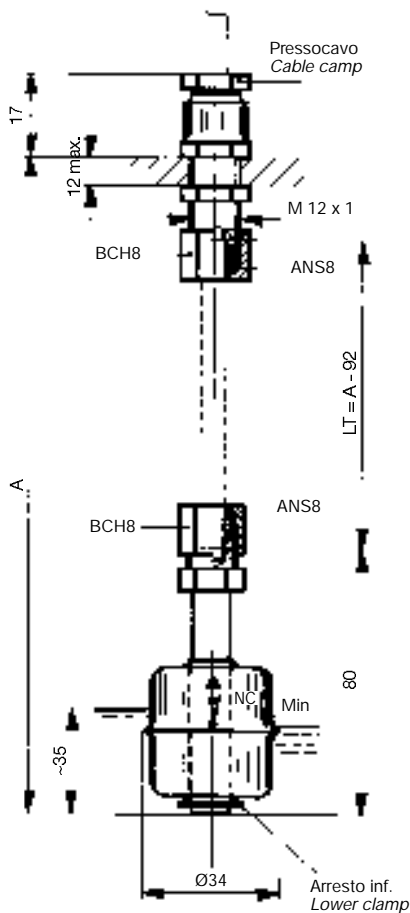

Schema di applicazione
Application chart

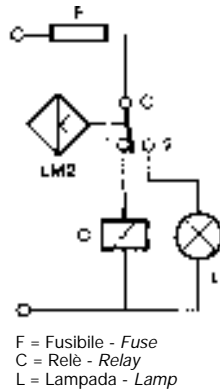

Collegamenti elettrici
Electrical connection

LM1PI-LM1BFI

Simboli
Symbol



LM2PI-LM2BFI

Simboli
Symbol

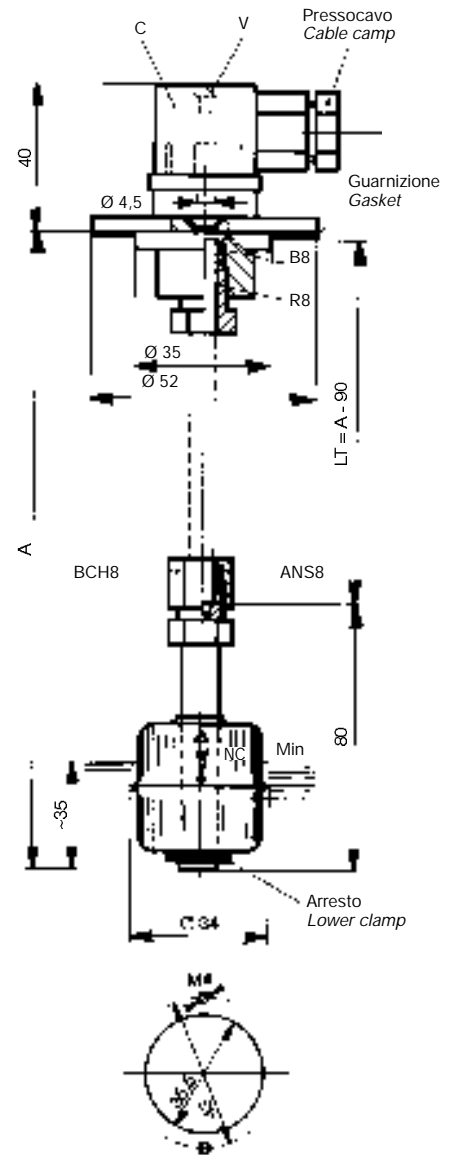
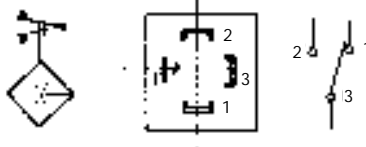

COSTRUZIONE: flangia, raccordo R8, bicono B8, bocchetto BCH8, anello di serraggio ANS8 e galleggiante in acciaio inox AISI 316.

IMPIEGO E DATI TECNICI (vedere pag. 1 - 2 - 3).

N.B. - Per un corretto funzionamento, serrare con cura i raccordi BCH8 e R8 in modo da ottenere un buon fissaggio e tenuta del tubo di acciaio inox Ø 6x8, onde evitare infiltrazioni di fluido nel livellostatato e comprometterne il funzionamento.

MATERIAL: flange, R8 fitting, B8 bicone, BCHB union, ANS8 fastening ring, body and float in AISI 316 stainless steel.

APPLICATION AND TECHNICAL DATA (see page 1 - 2 - 3).

N.B. - For a correct operation, fasten carefully the BCH8 and the R8 pipe fittings to obtain a firm seal of the Ø 6x8 stainless steel pipe and to avoid fluid leakage in the level indicator thus affecting its working.

LIVELLOSTATI ELETTROMAGNETICI - INOX

Electromagnetic level indicators - Stainless steel

Type **LM1FIA...**
LM2FIA...

Type **LMM1FIA...**

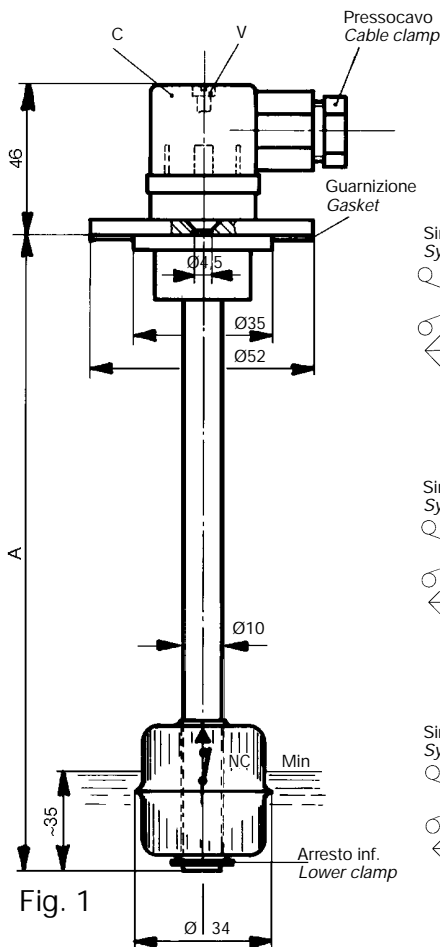

Collegamenti elettrici
Electrical connection

LM1FIA...

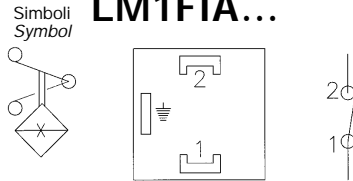

LM2FIA...

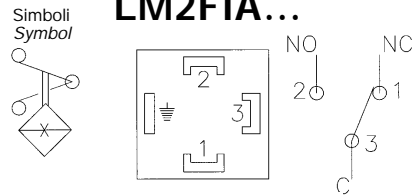

LMM1FIA...

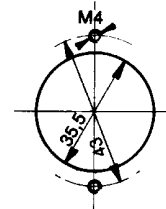
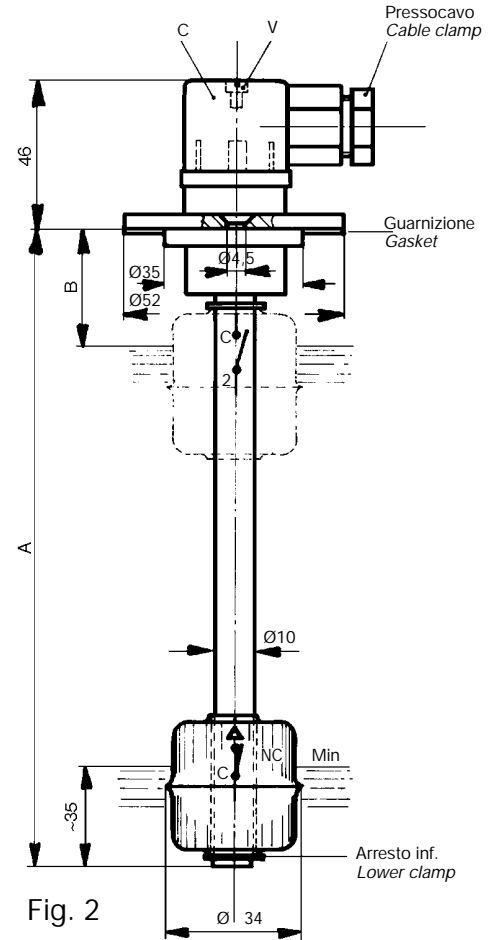
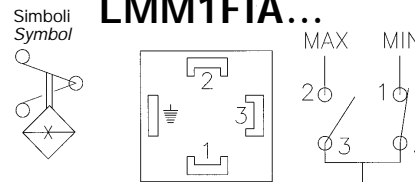

COSTRUZIONE: flangia in acciaio inox, tubo in inox, ed anelli di arresto in inox, galleggianti in inox.

MATERIAL: flange in stainless steel, tube in stainless steel, stop rings in stainless steel, float in stainless steel.

IMPIEGO E DATI TECNICI (vedere pag. 1 - 2 - 3).

APPLICATION AND TECHNICAL DATA (see page 1 - 2 - 3).

N.B. - A richiesta, forniamo lunghezze superiori, oppure diverse da quelle indicate in tabella.

N.B. - On customer's request we supply superior or different lengths from those indicated in the reference table.

FIGURA 1 Picture 1		FIGURA 2 Picture 2		
		A	B	
TIPO Type	TIPO Type			TIPO Type
LM1FIA150	LM2FIA150	150	50	LMM1FIA150B50
LM1FIA200	LM2FIA200	200	60	LMM1FIA200B60
LM1FIA250	LM2FIA250	250	60	LMM1FIA250B60
LM1FIA300	LM2FIA300	300	60	LMM1FIA300B60
LM1FIA350	LM2FIA350	350	60	LMM1FIA350B60
LM1FIA400	LM2FIA400	400	70	LMM1FIA400B70
LM1FIA450	LM2FIA450	450	70	LMM1FIA450B70
LM1FIA500	LM2FIA500	500	80	LMM1FIA500B80

LIVELLOSTATI ELETTROMAGNETICI - INOX

Electromagnetic level indicators - Stainless steel

Type LM1TIA...
LM2TIA...

Type LMM1TIA...

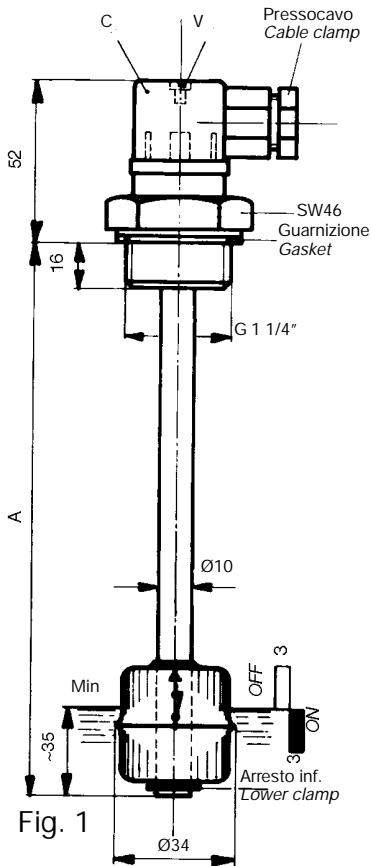

Fig. 1

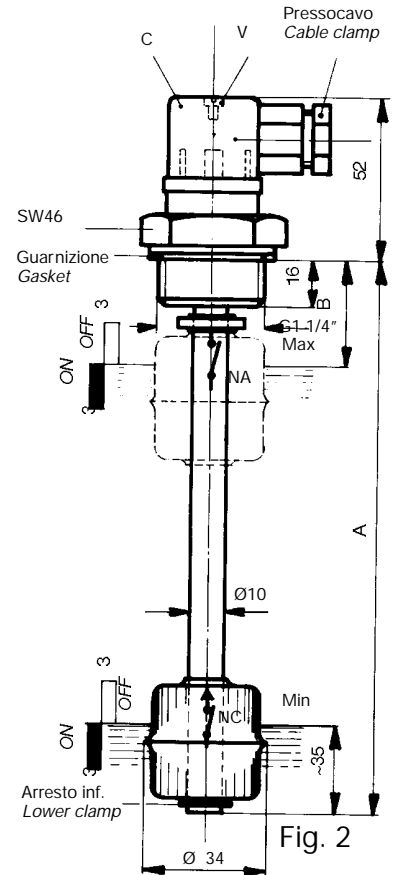
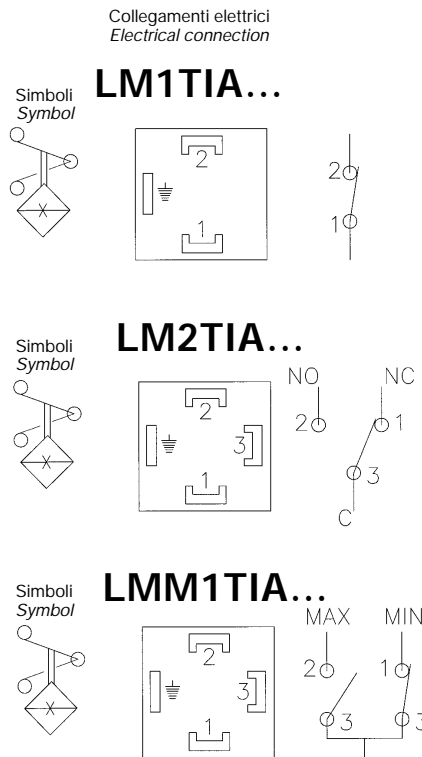

Fig. 2

COSTRUZIONE: flangia filettata G 1 1/4", tubo, anelli di arresto e galleggiante in acciaio inox.

IMPIEGO E DATI TECNICI (vedere pag. 1 - 2 - 3).

N.B. - A richiesta, forniamo lunghezze superiori, oppure diverse da quelle indicate in tabella.

MATERIAL: G1 1/4" threaded flange in stainless steel, stainless steel tube, stop rings in stainless steel, stainless steel float.

APPLICATION AND TECHNICAL DATA (see page 1 - 2 - 3).

N.B. - On customer's request we supply superior or different lengths from those indicated in the reference table.

FIGURA Picture 1		FIGURA Picture 2		
		A	B	
TIPO Type	TIPO Type			TIPO Type
LM1TIA150	LM2TIA150	150	50	LMM1TIA150B50
LM1TIA200	LM2TIA200	200	60	LMM1TIA200B60
LM1TIA250	LM2TIA250	250	60	LMM1TIA250B60
LM1TIA300	LM2TIA300	300	60	LMM1TIA300B60
LM1TIA350	LM2TIA350	350	60	LMM1TIA350B60
LM1TIA400	LM2TIA400	400	70	LMM1TIA400B70
LM1TIA450	LM2TIA450	450	70	LMM1TIA450B70
LM1TIA500	LM2TIA500	500	80	LMM1TIA500B80

LIVELLOSTATI ELETTROMAGNETICI

Electromagnetic level indicators

Type LM... GS... LMM1GS

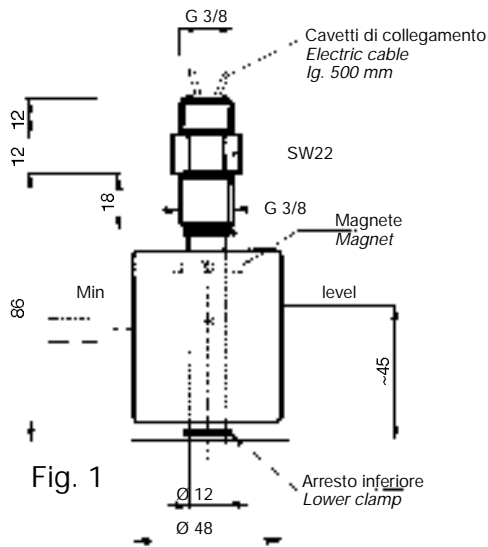

Schema di applicazione
Application chart

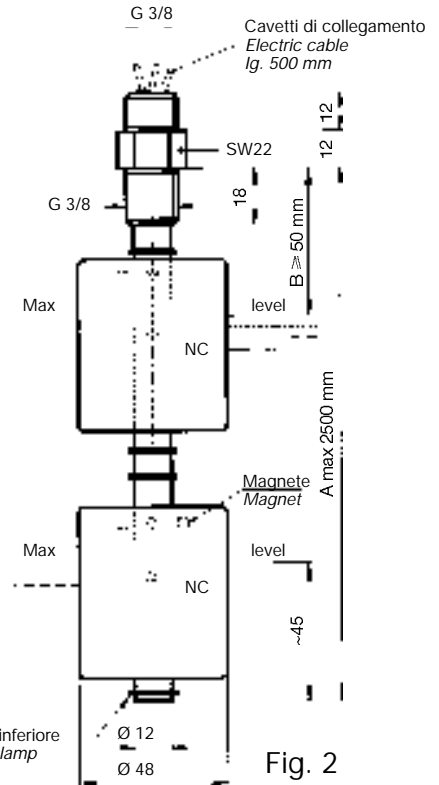
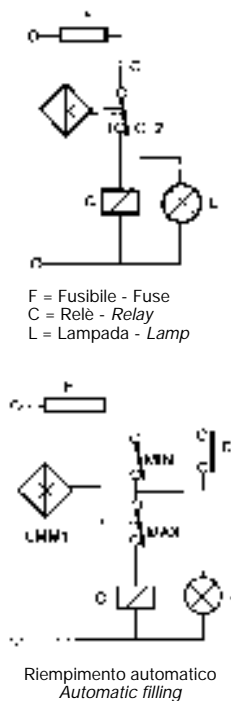
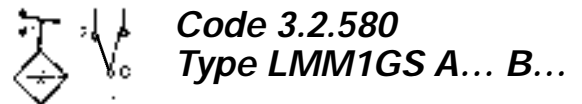
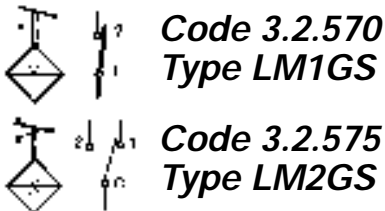

Fig. 2

N.B. - Nelle ordinazioni indicare le quote A e B.
N.B. - In the order indicate the dimensions A and B



IMPIEGO

Sono stati studiati per controllare il minimo o il massimo livello di un fluido contenuto in un serbatoio e per inviare un segnale elettrico di allarme a distanza. A seconda dei tipi devono essere applicati sul coperchio del serbatoio con giacitura verticale in modo che il galleggiante disti almeno 50 mm. dalle pareti metalliche.

DATI TECNICI

Potenza commutabile in CC	60 W
Potenza commutabile in CA	60 VA
Intensità di corrente	0.8 A (resistivi)
Tensione max. di lavoro	~220 V - 50 Hz
Tensione di breakdown	300 V
Capacità dei contatti aperti	0,6 pF
Contatti a riposo (senza fluido)	NC
Campo di temperatura	-10 +80°C
Resistenza d'isolamento	10 ¹⁰ OHM
Peso specifico del liquido	>0,7
Pressione massima	10 Bar
Viscosità del fluido	max 150 cSt
Contatti a riposo (senza fluido)	NC

CON CONTATTI SPDT "SC"

Potenza commutabile	30 W
Corrente commutabile in CC	0,5 A (resistivi)
Resistenza d'isolamento	10 ⁹ OHM min.
Capacità dei contatti	2 pF
Costruzione	Corpo ottone, galleggiante in NBR

USE

This series of electromagnetic level indicators has been designed to check the minimum or maximum level of a fluid in a tank and send an electric signal to a remote board in case the fluid goes over or under the set levels. These level indicators should be fixed vertically on the cover of the tank, with the float at least 50 mm far from metal walls.

TECHNICAL DATA

Power commutated in DC	60 W
Power commutated in AC	60 VA
Intensity of current	0.8 A (resistive)
Voltage	~220 V - 50 Hz
Breakdown voltage	300 V
Open contacts capacity	0,6 pF
Idle contact (without fluid)	NC
Temperature range	-10 +80°C
Insulation resistance	10 ¹⁰ OHM
Fluid specific weight	>0.7
Maximum pressure	10 Bar
Fluid viscosity	max 150 cSt
Idle contact (without fluid)	NC

WITH SPDT CONTACTS "Sc"

Power commutated	30 W
Intensity of current	0.5 A (resistive)
Insulation resistance	10 ⁹ OHM min.
Open contacts capacity	2 pF
Material	Brass body - NBR float

PER CARICHI INDUTTIVI IMPIEGARE CIRCUITO DI PROTEZIONE.

WITH INDUCTIVE LOADS A PROTECTION CIRCUIT IS TO BE USED.

LIVELLOSTATI ELETTROMAGNETICI

Electromagnetic level indicators

Type LM3 GSA... B... C...

su richiesta contatti NA o SPDT

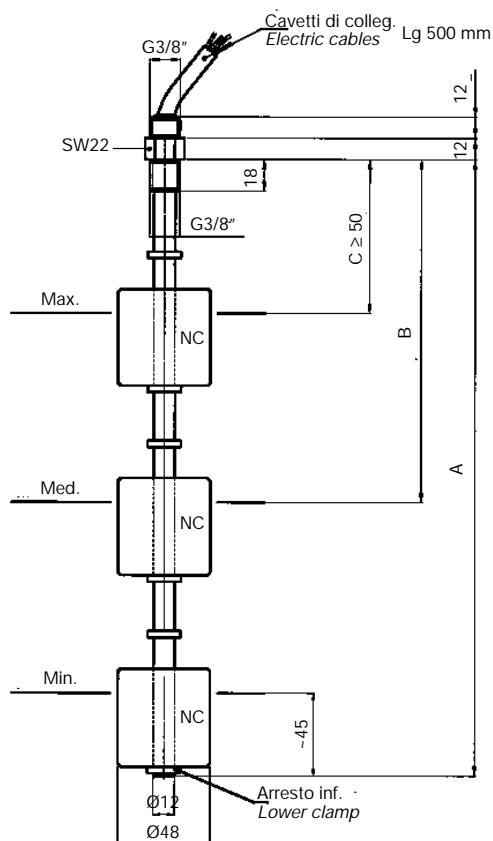

N.B. - Nelle ordinazioni indicare le quote A - B - C - D.
A max = 2500 mm - Min. distanza fra i contatti B - C - D = 90 mm.
Esempio di ordinazione: LM3GSA600B300C50

IMPIEGO

Sono stati studiati per controllare il livello di un fluido contenuto in un serbatoio e per inviare un segnale elettrico di allarme a distanza. A seconda dei tipi devono essere applicati sul coperchio del serbatoio con giacitura verticale in modo che il galleggiante disti almeno 50 mm. dalle pareti metalliche.

DATI TECNICI

Potenza commutabile in CC	60 W
Potenza commutabile in CA	60 VA
Intensità di corrente	0,8 A (resistivi)
Tensione max. di lavoro	~220 V - 50 Hz
Tensione di breakdown	300 V
Capacità dei contatti aperti	0,6 pF
Campo di temperatura	-10 +80°C
Resistenza d'isolamento	10 ¹⁰ OHM
Contatti (senza fluido)	NC
Peso specifico del liquido	≥0,7
Pressione massima	10 Bar
Viscosità del fluido	max 150 cSt
Contatti a riposo (senza fluido)	NC

CON CONTATTI SPDT "SC"

Potenza commutabile	30 W
Corrente commutabile in CC	0,5 A (resistivi)
Resistenza d'isolamento	10 ⁹ OHM min.
Capacità dei contatti	2 pF
Costruzione	Corpo ottone, galleggiante in NBR

PER CARICHI INDUTTIVI IMPIEGARE CIRCUITO DI PROTEZIONE.

Type LM4 GSA... B... C... D...

NO or SPDT contacts on request

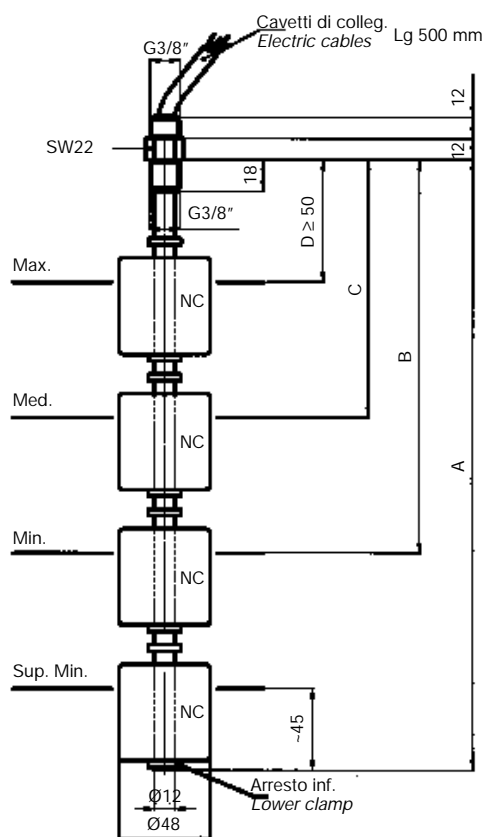

N.B. - When ordering indicate the dimensions A - B - C - D.
A max = 2500 mm - Min. contact distance B - C - D = 90 mm.
Example of order: LM3GSA600B300D50

USE

This series of electromagnetic level indicators has been designed to check the level in a tank, send an electric signal to a remote board in case the fluid goes over or under the established levels. These level indicators must be set vertically on the cover of the tank, with the float at least 50 mm far from the metal walls.

TECHNICAL DATA

Power commutated in DC	60 W
Power commutated in AC	60 VA
Intensity of current	0,8 A (resistive)
Voltage	~220 V - 50 Hz
Breakdown voltage	300 V
Open contacts capacity	0,6 pF
Temperature range	-10 +80°C
Insulation resistance	10 ¹⁰ OHM
Idle contact (without fluid)	NC
Fluid specific weight	≥0,7
Maximum pressure	10 Bar
Fluid viscosity	max 150 cSt
Idle contacts (without fluid)	NC

WITH SPDT CONTACTS "SC"

Power commutated	30 W
Intensity of current	0,5 A (resistive)
Insulation resistance	10 ⁹ OHM min.
Open contacts capacity	2 pF
Material	Brass body - NBR float

WITH INDUCTIVE LOADS A PROTECTION CIRCUIT IS TO BE USED.

LIVELLOSTATI ELETTROMAGNETICI

Electromagnetic level indicators

Type LM1GA...
LM2GA...

Collegamenti elettrici
Electrical connection

Type LMM1GA...

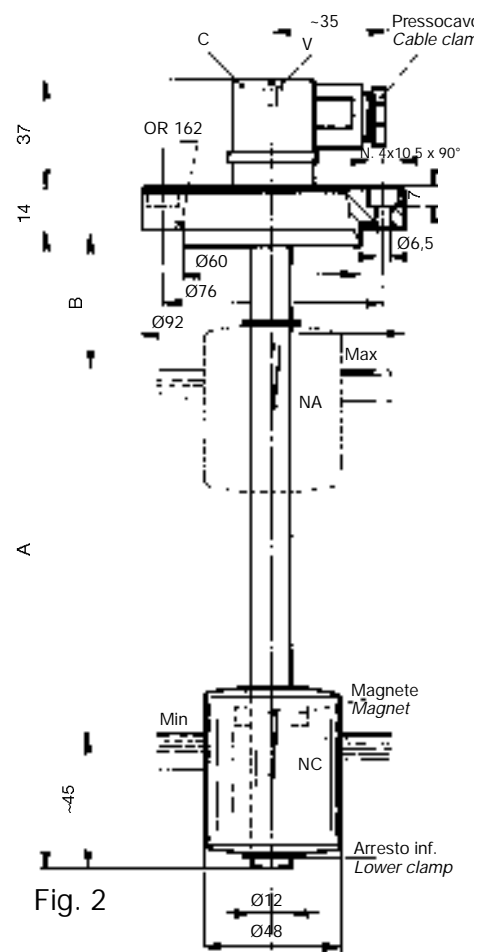
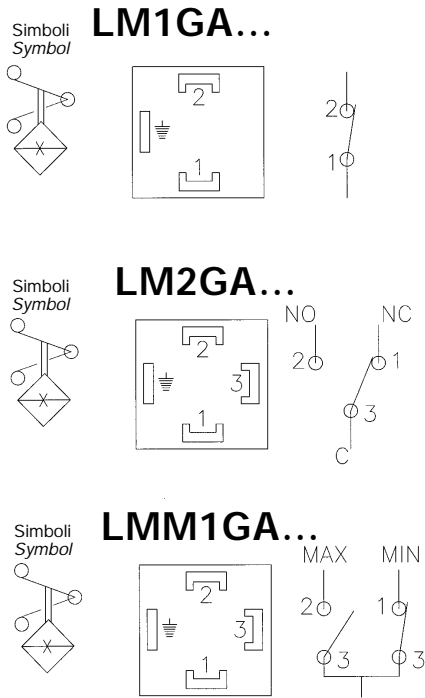
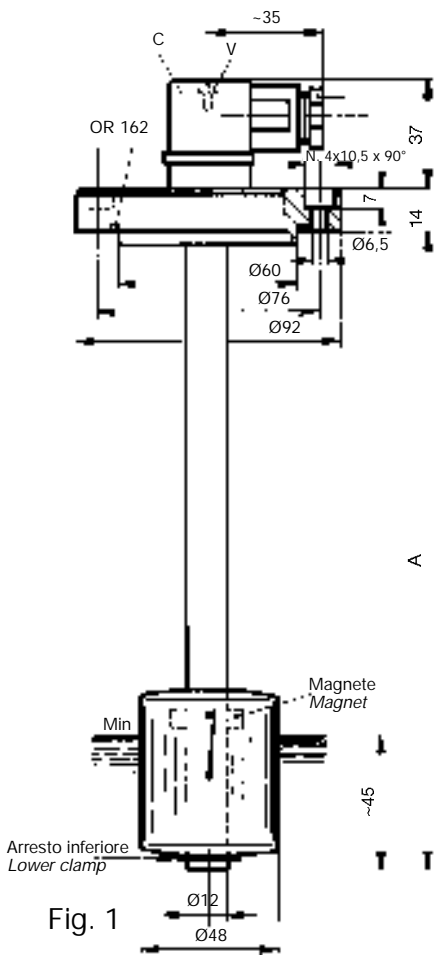

COSTRUZIONE: flangia in alluminio anodizzato, tubo in ottone, molla e anelli di arresto in bronzo, galleggiante in resina espansa NBR.

MATERIAL: flange in anodized aluminium; brass tube; spring and stop ring in bronze, NBR expanded resin float.

IMPIEGO E DATI TECNICI (vedere pag. 1 - 2 - 3).

APPLICATION AND TECHNICAL DATA (see page 1 - 2 - 3).

N.B. - A richiesta, forniamo lunghezze superiori, oppure diverse da quelle indicate in tabella.

N.B. - On customer's request we supply superior or different lengths from those indicated in the reference table.

FIGURA 1 Picture 1		FIGURA 2 Picture 2		
		A	B	
TIPO Type	TIPO Type			TIPO Type
LM1GA150	LM2GA150	150	50	LMM1GA150B50
LM1GA200	LM2GA200	200	60	LMM1GA200B60
LM1GA250	LM2GA250	250	60	LMM1GA250B60
LM1GA300	LM2GA300	300	60	LMM1GA300B60
LM1GA350	LM2GA350	350	60	LMM1GA350B60
LM1GA400	LM2GA400	400	70	LMM1GA400B70
LM1GA450	LM2GA450	450	70	LMM1GA450B70
LM1GA500	LM2GA500	500	80	LMM1GA500B80

LIVELLOSTATI ELETTROMAGNETICI

Electromagnetic level indicators

Type LM1GTA...
LM2GTA...

Type LMM1GTA...

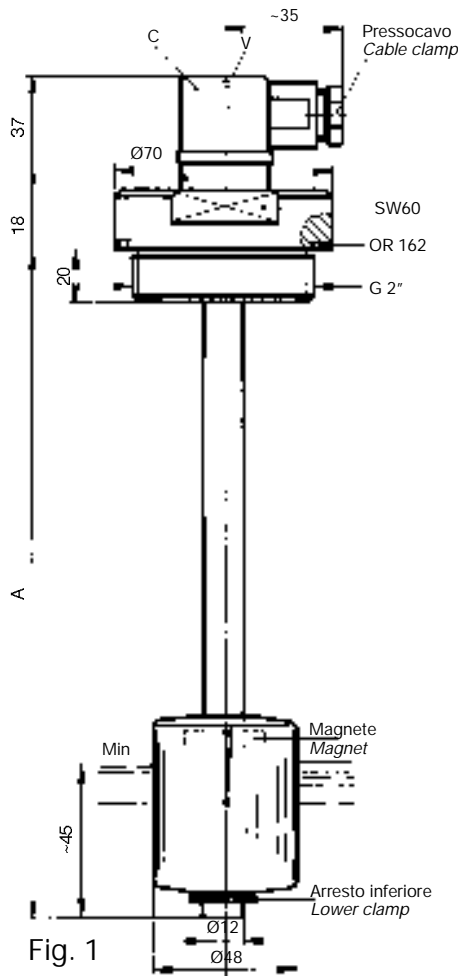

Fig. 1

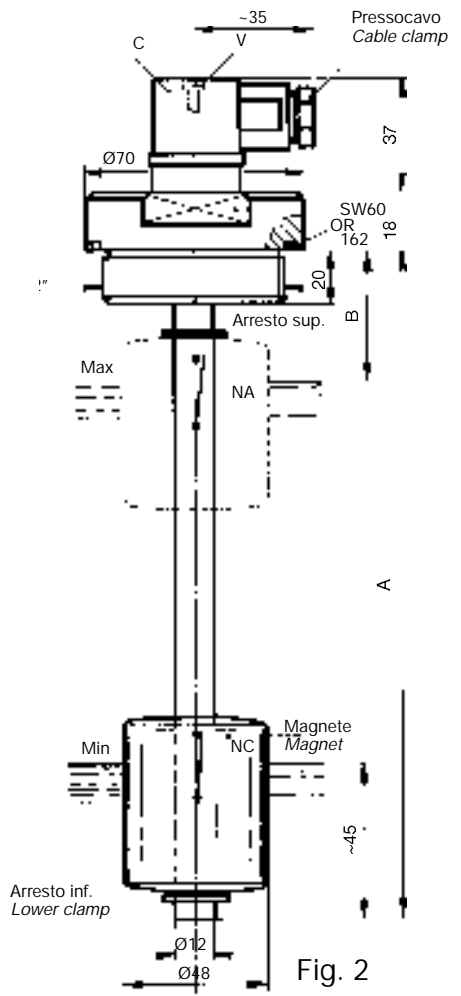
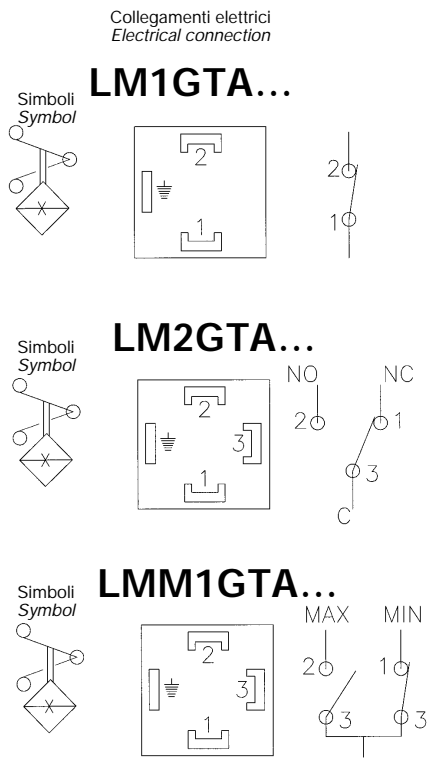

Fig. 2

COSTRUZIONE: flangia filettata in alluminio anodizzato, tubo in ottone, molla e anelli di arresto in bronzo, galleggiante in resina espansa NBR.

MATERIAL: threaded flange in anodized aluminium; brass tube; spring and stop ring in bronze; NBR expanded resin float.

IMPIEGO E DATI TECNICI (vedere pag. 1 - 2 - 3).

APPLICATION AND TECHNICAL DATA (see page 1 - 2 - 3).

N.B. - A richiesta, forniamo lunghezze superiori, oppure diverse da quelle indicate in tabella.

N.B. - On customer's request we supply superior or different lengths from those indicated in the reference table.

FIGURA 1 Picture 1		FIGURA 2 Picture 2		
		A	B	
TIPO Type	TIPO Type			TIPO Type
LM1GTA150	LM2GTA150	150	50	LMM1GTA150B50
LM1GTA200	LM2GTA200	200	60	LMM1GTA200B60
LM1GTA250	LM2GTA250	250	60	LMM1GTA250B60
LM1GTA300	LM2GTA300	300	60	LMM1GTA300B60
LM1GTA350	LM2GTA350	350	60	LMM1GTA350B60
LM1GTA400	LM2GTA400	400	70	LMM1GTA400B70
LM1GTA450	LM2GTA450	450	70	LMM1GTA450B70
LM1GTA500	LM2GTA500	500	80	LMM1GTA500B80

LIVELLOSTATI ELETTROMAGNETICI

Electromagnetic level indicators

Type LM4 GA... B... C... D...

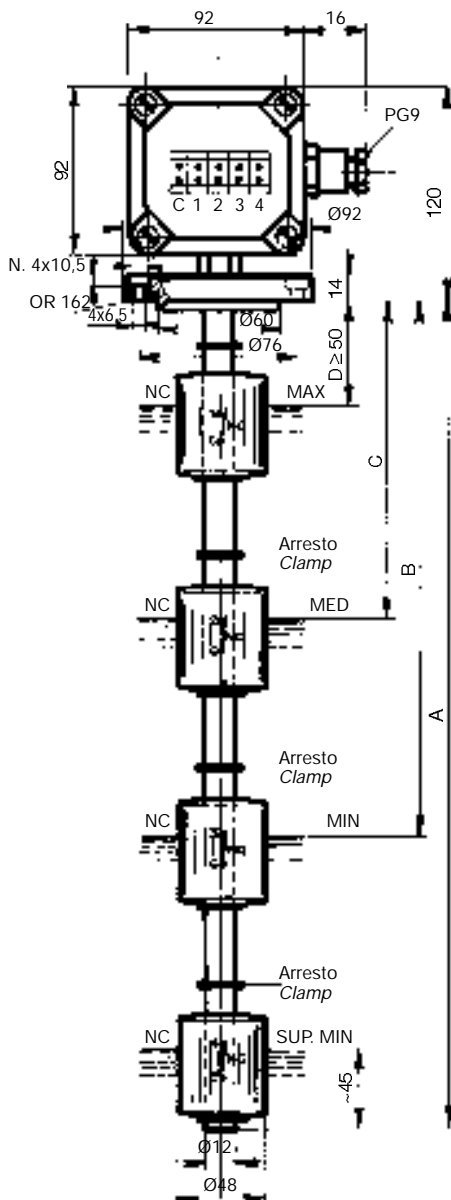

N.B. - Nelle ordinazioni indicare le quote A - B - C - D.
A max = 2500 mm - Min. distanza fra i contatti
B - C - D = 90 mm.

Esempio di ordinazione:
LM4GA800B600C200D50

Type LM3 GA... B... C... D...

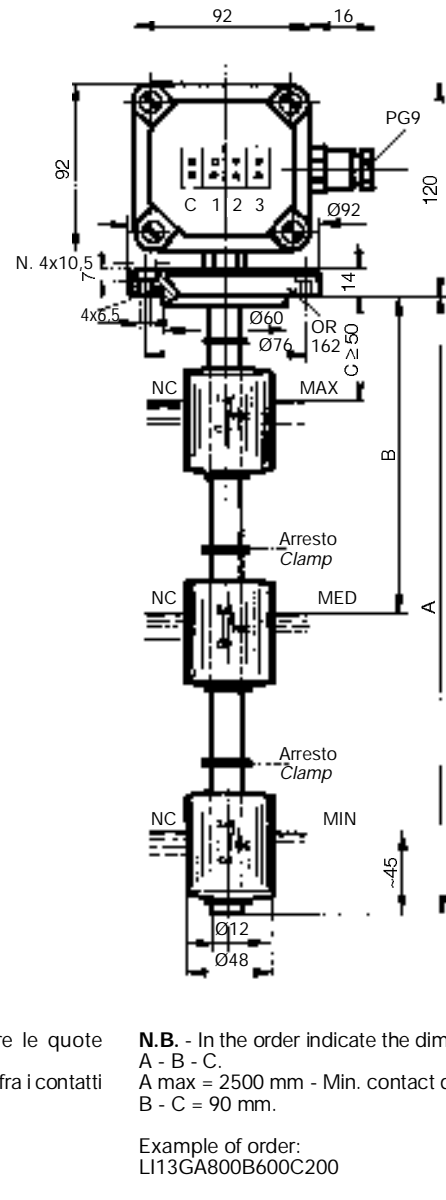

N.B. - In the order indicate the dimensions A - B - C.
A max = 2500 mm - Min. contact distance
B - C = 90 mm.

Example of order:
LI13GA800B600C200

IMPIEGO

Sono stati studiati per controllare il livello dell'olio, acqua, solventi, in un serbatoio e per inviare a distanza un segnale elettrico. A seconda dei tipi, devono essere applicati sul coperchio del serbatoio con giacitura verticale in modo che il galleggiante disti almeno 50 mm. dalle pareti metalliche.

DATI TECNICI

Lunghezza asta max	A = 2500 mm
Distanza min. fra B-C-D	90 mm
Potenza commutabile in CC	60 W
Potenza commutabile in CA	60 VA
Intensità di corrente	0,8 A (resistivi)
Tensione max. di lavoro	220 V - 50 Hz
Tensione di breakdown	300 V
Capacità dei contatti aperti	0,6 pF
Contatti a riposo (senza fluido)	NC (NA su richiesta)
Campo di temperatura	-10 +80°C
Resistenza d'isolamento	10 ¹⁰ OHM
Peso specifico liquido	≥ 0,7
Pressione massima	10 Bar
Viscosità del fluido	max 150 cSt

COSTRUZIONE: flangia in alluminio anodizzato, tubo in ottone, molla e anelli di arresto in bronzo, galleggiante in resina espansa NBR

PER CARICHI INDUTTIVI IMPIEGARE CIRCUITO DI PROTEZIONE.

USE

This series of electromagnetic level indicators has been designed to check the level of oil, water, solvents in a tank and send an electric signal to a remote board in case the fluid goes over or under the set levels. These level indicators should be fixed vertically on the cover of the tank, with the float at least 50 mm far from metal walls

TECHNICAL DATA

Level max length	A = 2500 mm
Distance min. B-C-D	90 mm
Power commutated in DC	60 W
Power commutated in AC	60 VA
Intensity of current	0.8 A (resistive)
Voltage	220 V - 50 Hz
Breakdown voltage	300 V
Open contacts capacity	0,6 pF
Idle contact (without fluid)	NC (NO on request)
Temperature range	-10 +80°C
Insulation resistance	10 ¹⁰ OHM
Fluid specific weight	≥ 0,7
Maximum pressure	10 Bar
Fluid viscosity	max 150 cSt

MATERIAL: flange in anodized aluminium; brass tube; spring and stop rings in bronze; NBR expanded resin float.

WITH INDUCTIVE LOADS A PROTECTION CIRCUIT IS TO BE USED.

LIVELLO STATI ELETTROMAGNETICI

Electromagnetic level indicators

Type LM3 GTA... B... C... D...

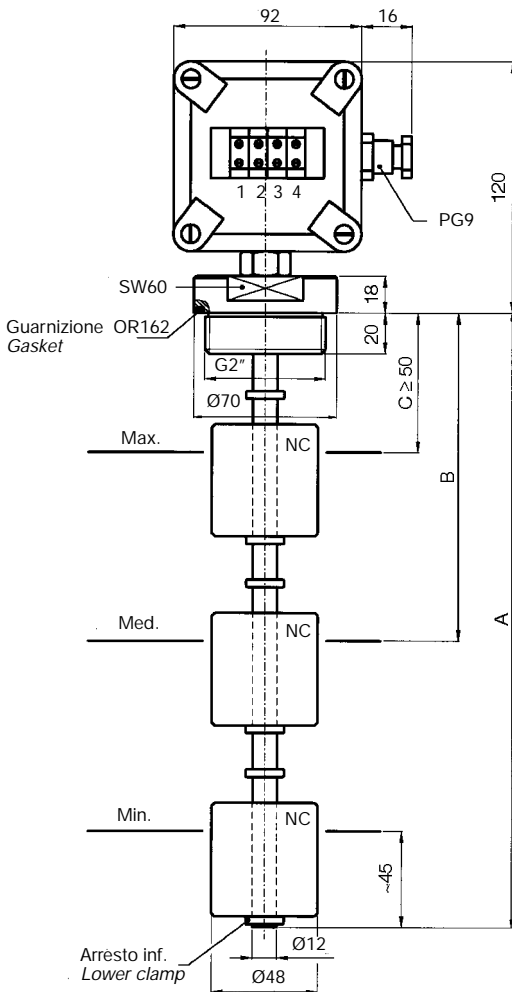

N.B. - Nelle ordinazioni indicare le quote A - B - C - D.
A max = 2500 mm - Min. distanza fra i contatti B - C - D = 90 mm.

COSTRUZIONE: flangia filettata in alluminio anodizzato, tubo in ottone, molla e anelli di arresto in bronzo, galleggiante in resina espansa NBR.

Esempio di ordinazione: LM3GTA600B400C200

IMPIEGO

Sono stati studiati per controllare il livello dell'olio, acqua, solventi, in un serbatoio e per inviare a distanza un segnale elettrico. A seconda dei tipi, devono essere applicati sul coperchio del serbatoio con giacitura verticale in modo che il galleggiante disti almeno 50 mm. dalle pareti metalliche.

DATI TECNICI

Lunghezza asta max	A = 2500 mm
Distanza min. fra B-C-D	90 mm
Potenza commutabile in CC	60 W
Potenza commutabile in CA	60 VA
Intensità di corrente	0,8 A (resistivi)
Tensione max. di lavoro	220 V - 50 Hz
Tensione di breakdown	300 V
Capacità dei contatti aperti	0,6 pF
Campo di temperatura	-10 +80°C
Contatto a riposo (senza fluido)	NC (NA su richiesta)
Resistenza d'isolamento	10 ¹⁰ OHM
Peso specifico liquido	≥ 0,7
Pressione massima	10 Bar
Viscosità del fluido	max 150 cSt

PER CARICHI INDUTTIVI IMPIEGARE CIRCUITO DI PROTEZIONE.

Type LM4 GTA... B... C... D...

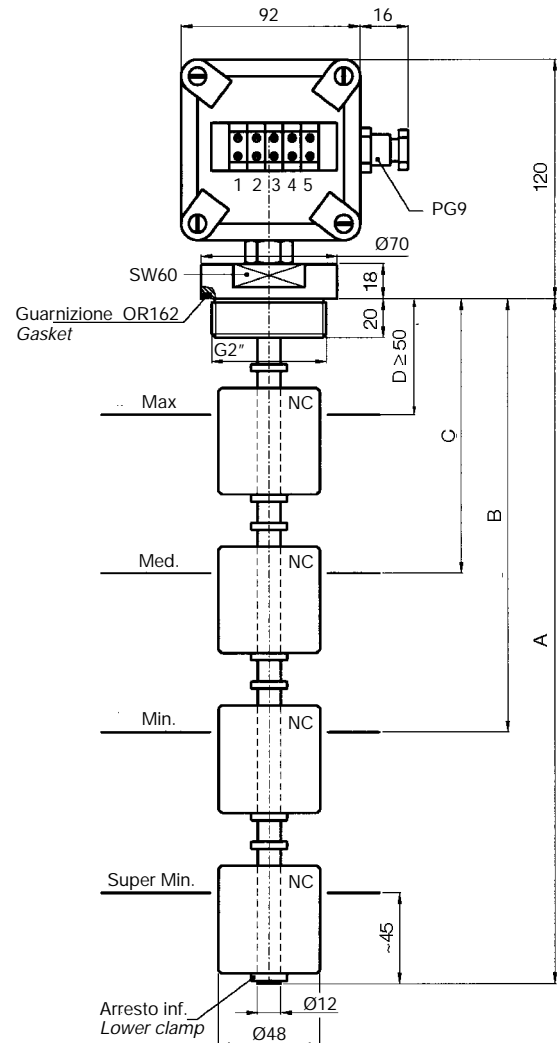

N.B. - In the order indicate the dimensions A - B - C - D.
A max = 2500 mm - Min. contact distance B - C - D = 90 mm.

MATERIAL: threaded flange in anodized aluminium; brass tube; spring and stop rings in bronze; NBR expanded resin float.

Example of order: LM4GTA1500B800C600D100

USE

This series of electromagnetic level indicators has been designed to check the level of oil, water, solvents in a tank and send an electric signal to a remote board in case the fluid goes over or under the set levels. These level indicators should be fixed vertically on the cover of the tank, with the float at least 50 mm far from metal walls

TECHNICAL DATA

Level max length	A = 2500 mm
Distance min. B-C-D	90 mm
Power commutated in DC	60 W
Power commutated in AC	60 VA
Intensity of current	0,8 A (resistive)
Voltage	220 V - 50 Hz
Breakdown voltage	300 V
Open contacts capacity	0,6 pF
Temperature range	-10 +80°C
Idle contact (without fluid)	NC (NO on request)
Insulation resistance	10 ¹⁰ OHM
Fluid specific weight	≥ 0,7
Maximum pressure	10 Bar
Fluid viscosity	max 150 cSt

WITH INDUCTIVE LOADS A PROTECTION CIRCUIT IS TO BE USED.

LIVELLOSTATI ELETTROMAGNETICI - INOX

Electromagnetic level indicators - Stainless steel

Type LM1GSI
LM2GSI

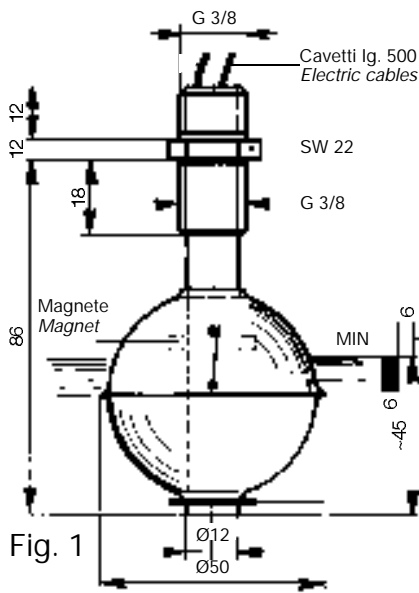

Simbolo
Symbol



Code 3.2.550
Type LM1GSI

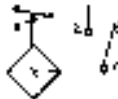

Code 3.2.551
Type LM2GSI

Schema di applicazione
Application chart

TYPE LM2GSI

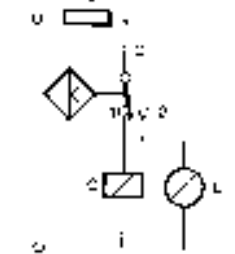

F = Fusibile - Fuse
C = Relè - Relay
L = Lampada - Lamp

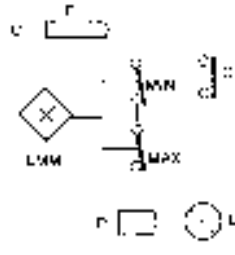

Riempimento automatico
Automatic filling

Type LMM1GSI A... B...

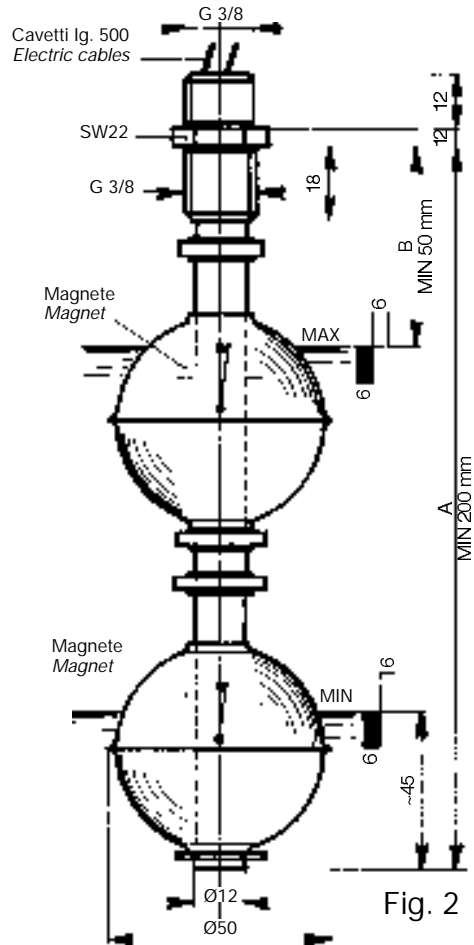

N.B. Nelle ordinazioni indicare le quote A e B.
N.B. In the order indicate the dimensions A and B.

Code 3.2.552
Type LMM1GSI A... B...

IMPIEGO

Sono stati studiati per controllare il minimo o il massimo livello dell'olio, acqua, solventi, in un serbatoio e inviare a distanza un segnale elettrico. A seconda dei tipi, devono essere applicati sul coperchio del serbatoio con giacitura verticale in modo che il galleggiante disti almeno 50 mm. dalle pareti metalliche.

DATI TECNICI

Potenza commutabile in CC	60 W
Potenza commutabile in CA	60 VA
Intensità di corrente	0.8 A (resistivi)
Tensione max. di lavoro	220 V - 50 Hz
Tensione di breakdown	300 V
Capacità dei contatti aperti	0,6 pF
Campo di temperatura	-10 +80°C
Resistenza d'isolamento	10 ¹⁰ OHM min.
Contatto a riposo (senza fluido)	NC

CON CONTATTI SPDT "SC"

Potenza commutabile	30 W
Corrente commutabile	0,5 A (resistivi)
Resistenza d'isolamento	10 ⁹ OHM min.
Capacità dei contatti	2 pF
Peso specifico liquido	≥ 0,7
Pressione massima	10 Bar
Viscosità del fluido	max 150 cSt
Costruzione	Acciaio inox AISI 316

PER CARICHI INDUTTIVI IMPIEGARE CIRCUITO DI PROTEZIONE.

USE

This series of electromagnetic level indicators has been designed to check the minimum or maximum level of oil, water, solvents in a tank and send an electric signal to a remote board in case the fluid goes over or under the set levels. These level indicators should be fixed vertically on the cover of the tank, with the float at least 50 mm far from metal walls.

TECHNICAL DATA

Power commutated in DC	60 W
Power commutated in AC	60 VA
Intensity of current	0.8 A (resistive)
Voltage	220 V - 50 Hz
Breakdown voltage	300 V
Open contacts capacity	0,6 pF
Temperature range	-10 +80°C
Insulation resistance	10 ¹⁰ OHM
Idle contact (without fluid)	NC

WITH SPDT CONTACTS "SC"

Power commutated	30 W
Intensity of current	0.5 A (resistive)
Insulation resistance	10 ⁹ OHM min.
Open contacts capacity	2 pF
Fluid specific weight	≥ 0,7
Maximum pressure	5 Bar
Fluid viscosity	max 150 cSt
Material	Stainless steel AISI 316

WITH INDUCTIVE LOADS A PROTECTION CIRCUIT IS TO BE USED.

LIVELLOSTATI ELETTROMAGNETICI - INOX

Electromagnetic level indicators - Stainless steel

LM3 GSIA... B... C...

Su richiesta contatti NA o SPDT

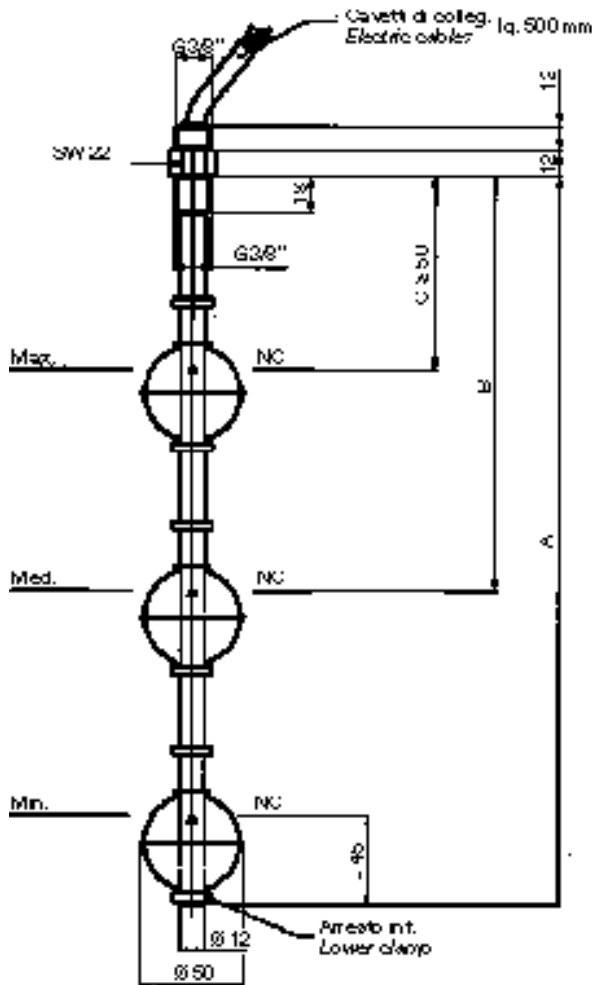

LM4 GSIA... B... C... D...

NO or SPDT contact on request

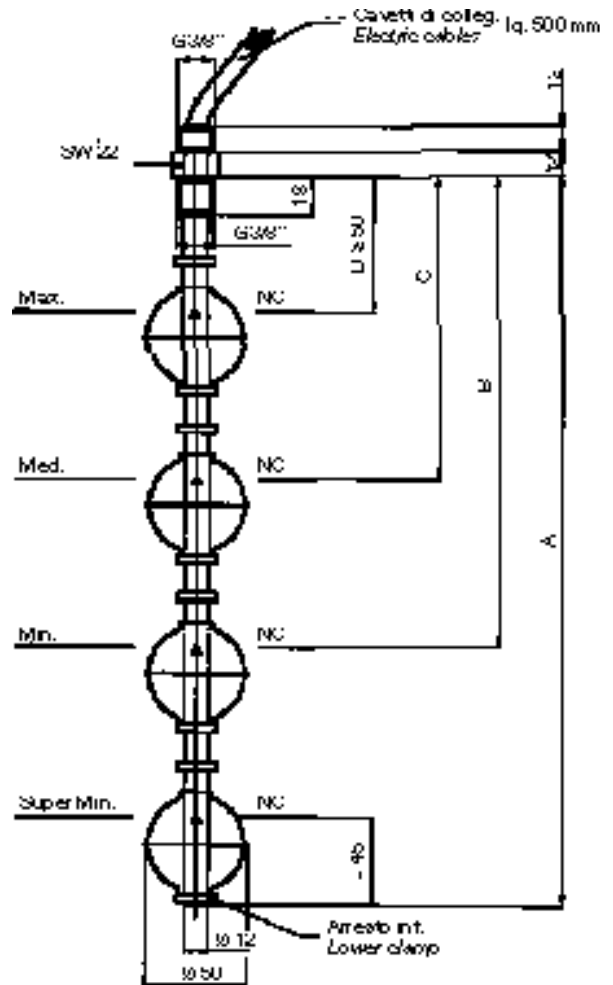

N.B. - Nelle ordinazioni indicare le quote A - B - C.
A max = 2500 mm - Min. distanza fra i contatti B - C = 90 mm.
Esempio di ordinazione: LM3GSIA1000B800C50

N.B. - In the order indicate the dimensions A - B - C - D.
A max = 2500 mm - Min contact distance B - C - D = 90 mm.
Example of order: LM4GSIA1000B800C600D400

IMPIEGO

Sono stati studiati per controllare il minimo o il massimo livello dell'olio, acqua, solventi, in un serbatoio e inviare a distanza un segnale elettrico. A seconda dei tipi, devono essere applicati sul coperchio del serbatoio con giacitura verticale in modo che il galleggiante disti almeno 50 mm. dalle pareti metalliche.

USE

This series of electromagnetic level indicators has been designed to check the minimum or maximum level of oil, water, solvents in a tank and send an electric signal to a remote board in case the fluid goes over or under the set levels. These level indicators should be fixed vertically on the cover of the tank, with the float at least 50 mm far from metal walls.

DATI TECNICI

Potenza commutabile in CC	60 W
Potenza commutabile in CA	60 VA
Intensità di corrente	0.8 A (resistivi)
Tensione max. di lavoro	220 V - 50 Hz
Tensione di breakdown	300 V
Capacità dei contatti aperti	0,6 pF
Campo di temperatura	-10 +80°C
Resistenza d'isolamento	10 ¹⁰ OHM min.
Contatto a riposo (senza fluido)	NC

CON CONTATTI SPDT "SC"

Potenza commutabile	30 W
Corrente commutabile	0,5 A (resistivi)
Resistenza d'isolamento	10 ⁸ OHM min.
Capacità dei contatti	2 pF
Peso specifico liquido	≥ 0,7
Pressione massima	10 Bar
Viscosità del fluido	max 150 cSt
Costruzione	Acciaio inox AISI 316

TECHNICAL DATA

Power commutated in DC	60 W
Power commutated in AC	60 VA
Intensity of current	0.8 A (resistive)
Voltage	220 V - 50 Hz
Breakdown voltage	300 V
Open contacts capacity	0,6 pF
Temperature range	-10 +80°C
Insulation resistance	10 ¹⁰ OHM
Idle contacts (without fluid)	NC

WITH SPDT CONTACTS "SC"

Power commutated	30 W
Intensity of current	0.5 A (resistive)
Insulation resistance	10 ⁸ OHM min.
Open contacts capacity	2 pf
Fluid specific weight	≥ 0,7
Maximum pressure	5 Bar
Fluid viscosity	max 150 cSt
Material	Stainless steel AISI 316

PER CARICHI INDUTTIVI IMPIEGARE CIRCUITO DI PROTEZIONE.

WITH INDUCTIVE LOADS A PROTECTION CIRCUIT IS TO BE USED.

LIVELLOSTATI ELETTROMAGNETICI - INOX

Electromagnetic level indicators - Stainless steel

Type **LM1GIA...**
LM2GIA...

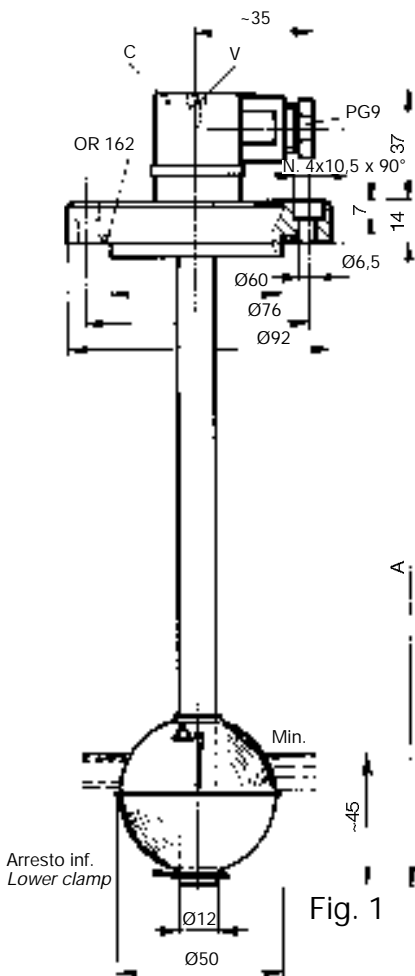
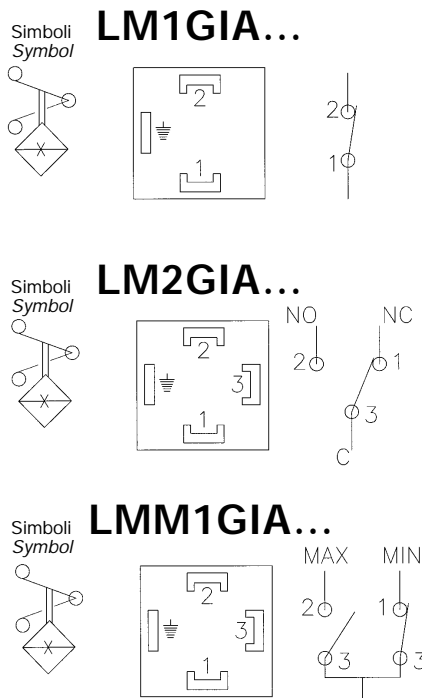

Fig. 1

Collegamenti elettrici
Electrical connection



Type **LMM1GIA...**

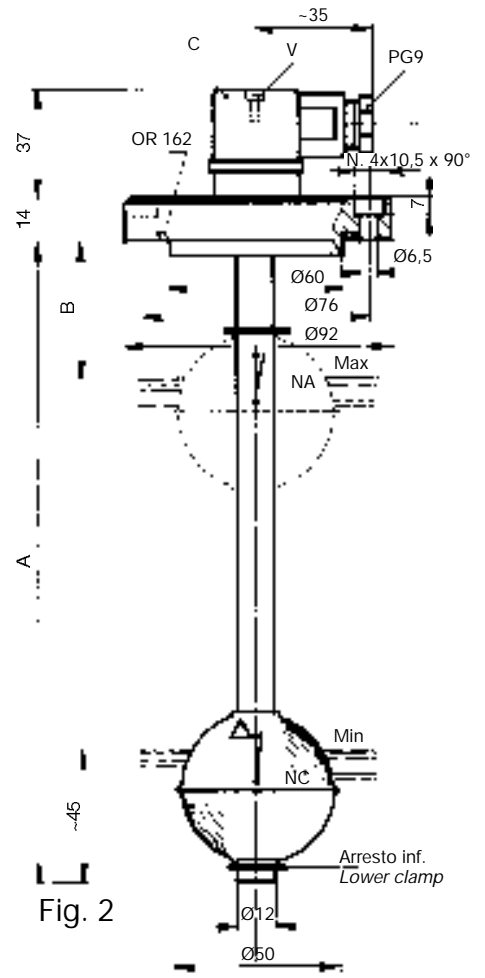

Fig. 2

COSTRUZIONE: flangia in acciaio inox, tubo in inox, ed anelli di arresto in inox, galleggiante in inox.

IMPIEGO E DATI TECNICI (vedere pag. 1 - 2 - 3).

N.B. - A richiesta, forniamo lunghezze superiori, oppure diverse da quelle indicate in tabella.

MATERIAL: flange in stainless steel, tube in stainless steel, stop rings in stainless steel, float in stainless steel.

APPLICATION AND TECHNICAL DATA (see page 1 - 2 - 3).

N.B. - On customer's request we supply superior or different lengths from those indicated in the reference table.

FIGURA 1 Picture 1		FIGURA 2 Picture 2		
		A	B	
TIPO Type	TIPO Type			TIPO Type
LM1GIA150	LM2GIA150	150	50	LMM1GIA150B50
LM1GIA200	LM2GIA200	200	60	LMM1GIA200B60
LM1GIA250	LM2GIA250	250	60	LMM1GIA250B60
LM1GIA300	LM2GIA300	300	60	LMM1GIA300B60
LM1GIA350	LM2GIA350	350	60	LMM1GIA350B60
LM1GIA400	LM2GIA400	400	70	LMM1GIA400B70
LM1GIA450	LM2GIA450	450	70	LMM1GIA450B70
LM1GIA500	LM2GIA500	500	80	LMM1GIA500B80

LIVELLOSTATI ELETTROMAGNETICI - INOX

Electromagnetic level indicators - Stainless steel

Type LM1GTIA...
LM2GTIA...

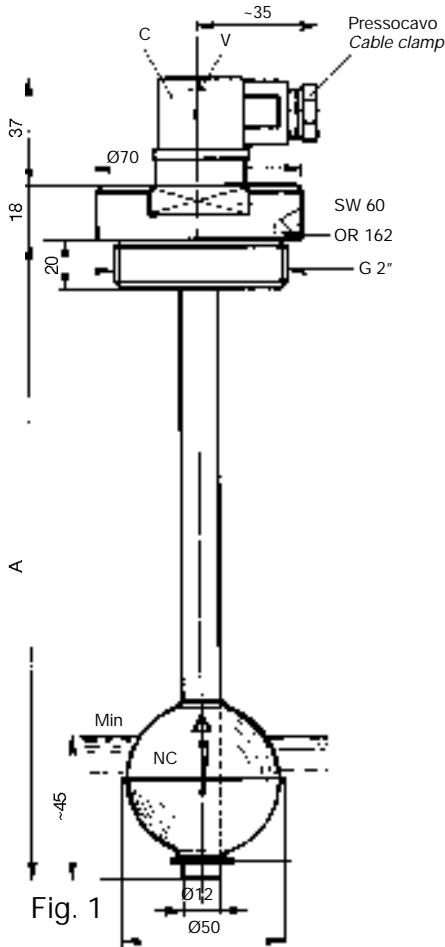

Type LMM1GTIA...

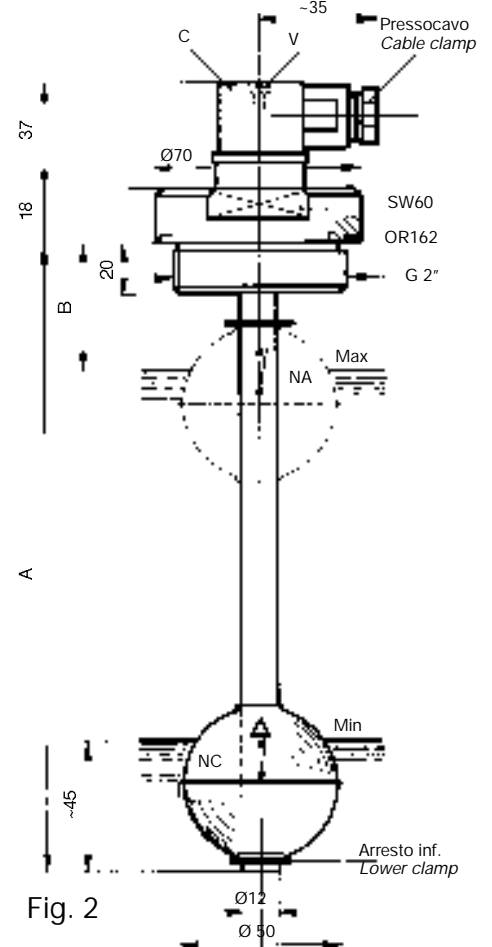

Collegamenti elettrici
Electrical connection

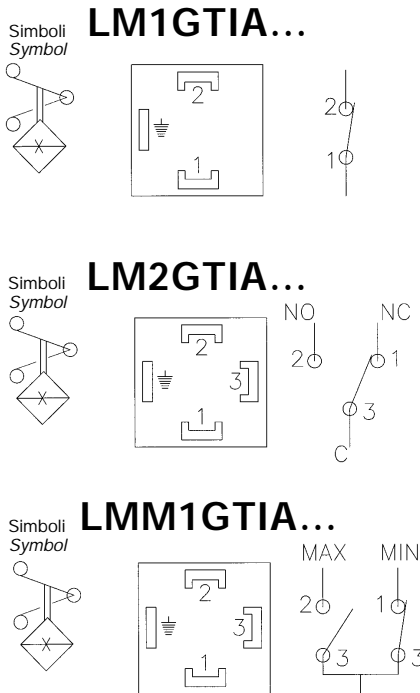

COSTRUZIONE: flangia filettata in acciaio inox, tubo in inox, ed anelli di arresto in inox, galleggiante in inox.

IMPIEGO E DATI TECNICI (vedere pag. 1 - 2 -3).

N.B. - A richiesta, forniamo lunghezza superiori, oppure diverse da quelle indicate in tabella.

MATERIAL: threaded flange in stainless steel, tube in stainless steel, stop rings in stainless steel, float in stainless steel.

APPLICATION AND TECHNICAL DATA (see page 1 - 2 -3).

N.B. - On customer's request we supply superior or different lengths from those indicated in the reference table.

FIGURA 1 Picture 1		FIGURA 2 Picture 2		
		A	B	
TIPO Type	TIPO Type			TIPO Type
LM1GTIA150	LM2GTIA150	150	50	LMM1GTIA150B50
LM1GTIA200	LM2GTIA200	200	60	LMM1GTIA200B60
LM1GTIA250	LM2GTIA250	250	60	LMM1GTIA250B60
LM1GTIA300	LM2GTIA300	300	60	LMM1GTIA300B60
LM1GTIA350	LM2GTIA350	350	60	LMM1GTIA350B60
LM1GTIA400	LM2GTIA400	400	70	LMM1GTIA400B70
LM1GTIA450	LM2GTIA450	450	70	LMM1GTIA450B70
LM1GTIA500	LM2GTIA500	500	80	LMM1GTIA500B80

LIVELLOSTATI ELETTROMAGNETICI - INOX

Electromagnetic level indicators - Stainless steel

Type LM3 GTIA... B... C...

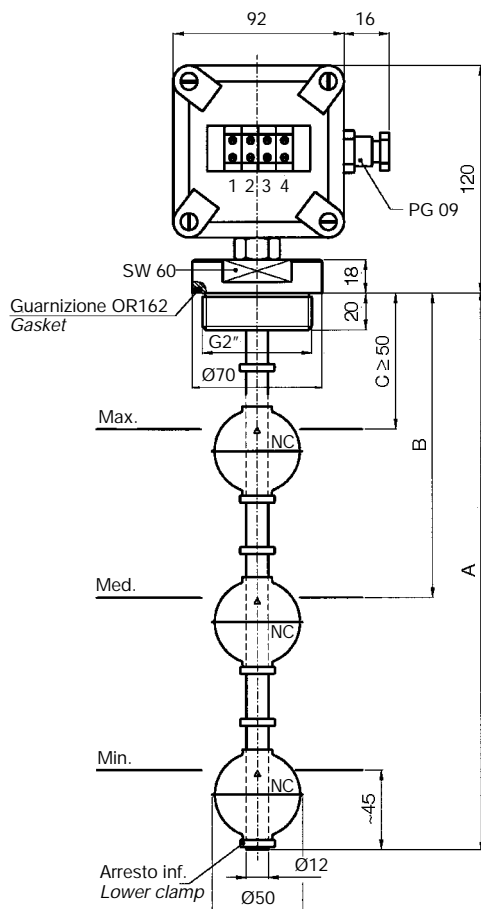

N.B. - Nelle ordinazioni indicare le quote A - B - C.
A max = 2500 mm - Min. distanza fra i contatti B - C = 90 mm.

Esempio di ordinazione: LM3GTIA1000B600C200

COSTRUZIONE: flangia filettata in acciaio inox, tubo in inox, ed anelli di arresto in inox, galleggianti in inox.

IMPIEGO

Sono stati studiati per controllare il livello dell'olio, acqua, solventi, in un serbatoio e per inviare a distanza un segnale elettrico. A seconda dei tipi, devono essere applicati sul coperchio del serbatoio con giacitura verticale in modo che il galleggiante disti almeno 50 mm. dalle pareti metalliche.

DATI TECNICI

Lunghezza asta max	A = 2500 mm
Potenza commutabile in CC	60 W
Potenza commutabile in CA	60 VA
Intensità di corrente	0.8 A (resistivi)
Tensione max. di lavoro	220 V - 50 Hz
Tensione di breakdown	300 V
Capacità dei contatti aperti	0,6 pF
Contatto a riposo (senza fluido)	NC (NA su richiesta)
Campo di temperatura	-10 +80°C
Resistenza d'isolamento	10 ¹⁰ OHM
Peso specifico liquido	≥ 0,7
Pressione massima	10 Bar
Viscosità del fluido	max 150 cSt

PER CARICHI INDUTTIVI IMPIEGARE CIRCUITO DI PROTEZIONE.

Type LM4 GTIA... B... C... D...

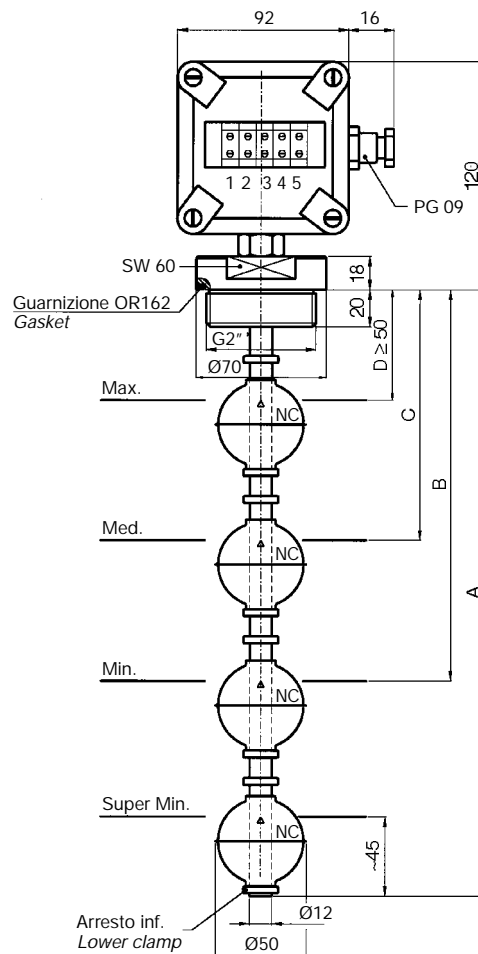

N.B. - In the order indicate the dimensions A - B - C - D.
A max = 2500 mm - Min. contact distance B - C - D = 90 mm.

Example of order: LM4GTIA1500B1200C200D50

MATERIAL: threaded flange in stainless steel, tube in stainless steel, stop rings in stainless steel, float in stainless steel.

USE

This series of electromagnetic level indicators has been designed to check the level of oil, water, solvents in a tank and send an electric signal to a remote board in case the fluid goes over or under the set levels. These level indicators should be fixed vertically on the cover of the tank, with the float at least 50 mm far from metal walls.

TECHNICAL DATA

Level max length	A = 2500 mm
Power commutated in DC	60 W
Power commutated in AC	60 VA
Intensity of current	0.8 A (resistive)
Voltage	220 V - 50 Hz
Breakdown voltage	300 V
Open contacts capacity	0,6 pF
Idle contact (without fluid)	NC (NO on request)
Temperature range	-10 +80°C
Insulation resistance	10 ¹⁰ OHM
Fluid specific weight	≥ 0,7
Maximum pressure	10 Bar
Fluid viscosity	max 150 cSt

WITH INDUCTIVE LOADS A PROTECTION CIRCUIT IS TO BE USED.

LIVELLOSTATI ELETTROMAGNETICI - ESEC. ANTIDEFAGRANTE

Electromagnetic level indicators - Explosion Proof execution

EExd II CT6 - EN 50014 - 18

Type LM1CTA... EP LM2CTA... EP

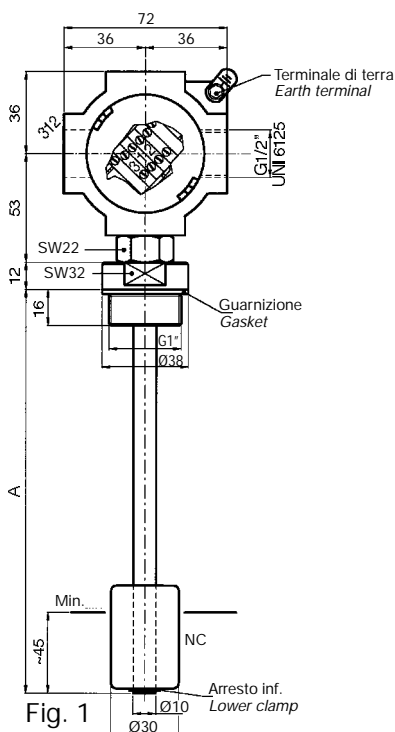

Collegamenti elettrici
Electrical connection

LM1CTA... EP

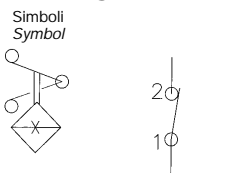

LM2CTA... EP

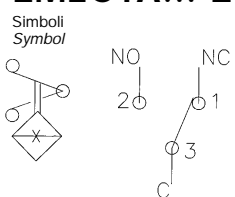

LMM1CTA... EP

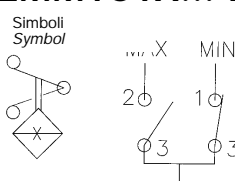

Type LMM1CTA... EP

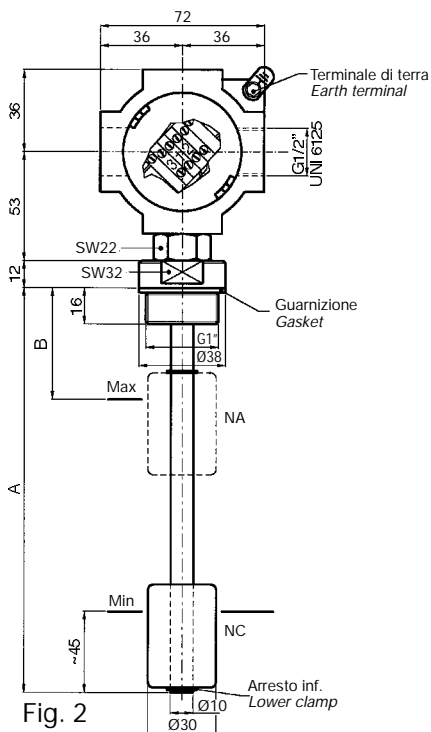

COSTRUZIONE: flangia filettata in ottone, tubo in ottone, anelli di arresto in bronzo, galleggianti in resina espansa NBR, custodia in alluminio pressofuso verniciato.

N.B. - A richiesta, forniamo lunghezza superiori, oppure diverse da quelle indicate in tabella.

IMPIEGO

Sono stati studiati per controllare il livello dell'olio, acqua, solventi, in un serbatoio e per inviare a distanza un segnale elettrico. A seconda dei tipi, devono essere applicati sul coperchio del serbatoio con giacitura verticale in modo che il galleggiante disti almeno 50 mm. dalle pareti metalliche.

DATI TECNICI COMUNI

Lunghezza asta max	A = 1500 mm
Campo di temperatura	-20 ÷ +40°C
Peso specifico liquido	≥ 0,8
Pressione massima	10 Bar
Viscosità del fluido	max 150 cSt

DATI TECNICI LM1 - LMM1

Potenza commutabile in CC/CA	60 W/VA
Intensità di corrente	0,8 A (resistivi)
Tensione di lavoro	220 V - 50 Hz
Tensione di breakdown	300 V
Capacità dei contatti aperti	0,6 pF
Resistenza d'isolamento	10 ¹⁰ Ohm
Contatto a riposo (senza fluido)	
Livello min. (LM1-LMM1)	NC (NA su richiesta)
Livello max (LMM1)	NC (NA su richiesta)

DATI TECNICI LM2

Potenza commutabile in CC/CA	30 W/VA
Intensità di corrente	0,5 A (resistivi)
Tensione di lavoro	220 V - 50 Hz
Tensione di breakdown	300 V
Capacità dei contatti aperti	2 pF
Resistenza d'isolamento	10 ¹⁰ Ohm

MATERIAL: threaded flange in brass; brass tube; stop ring in bronze; NBR expanded resin float, varnished die-cast aluminium housing.

N.B. - On customer's request we supply superior or different lengths from those indicated in the reference table.

USE

This series of electromagnetic level indicators has been designed to check a fluid level in a tank and send an electric signal to a remote board. These level indicators must be set vertically on the cover of the tank, with the float at least 50 mm far from metal walls.

STANDARD TECHNICAL DATA

Level max length	A = 1500 mm
Temperature range	-20 ÷ +40°C
Fluid specific weight	≥ 0,8
Maximum pressure	10 Bar
Fluid viscosity	max 150 cSt

LM1-LMM1 TECHNICAL DATA

Power commutated in DC/AC	60 W/VA
Intensity of current	0,8 A (resistive)
Voltage	220 V - 50 Hz
Breakdown voltage	300 V
Open contacts capacity	0,6 pF
Insulation resistance	10 ¹⁰ Ohm
Idle contact (without fluid)	
Min level (LM1-LMM1)	NC (NO on request)
Max level (LMM1)	NC (NO on request)

LM2 TECHNICAL DATA

Power commutated in DC/AC	30 W/VA
Intensity of current	0,5 A (resistive)
Voltage	220 V - 50 Hz
Breakdown voltage	300 V
Open contacts capacity	2 pF
Insulation resistance	10 ¹⁰ Ohm

LIVELLOSTATI ELETTROMAGNETICI - INOX - ESEC. ANTIDEFAGRANTE

Electromagnetic level indicators - Stainless steel - Explosion Proof execution

EExd II CT6 - EN 50014 - 18

Type LM1TIA... EP LM2TIA... EP

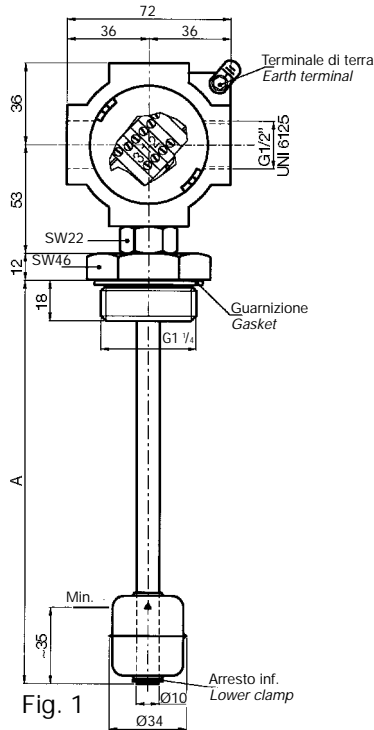

Collegamenti elettrici
Electrical connection

LM1TIA... EP

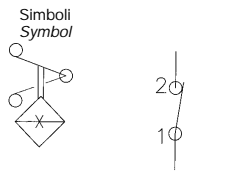

LM2TIA... EP

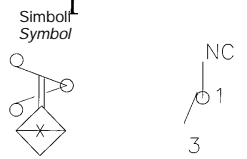

LMM1TIA... EP

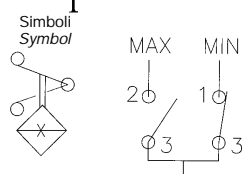

Type LMM1TIA... B... EP

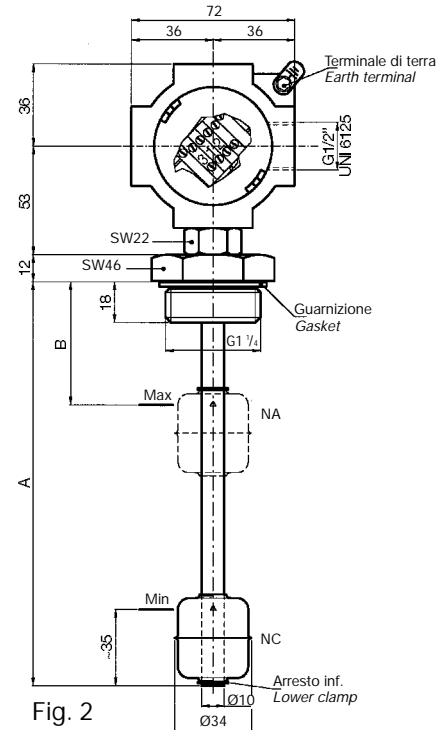

Fig. 2

COSTRUZIONE: flangia filettata G1 1/4" in inox; tubo in inox; anelli di arresto in inox; galleggiante in inox, custodia in alluminio pressofuso verniciato.

N.B. - A richiesta, forniamo lunghezza superiori, oppure diverse da quelle indicate in tabella.

IMPIEGO

Sono stati studiati per controllare il livello dell'olio, acqua, solventi, in un serbatoio e per inviare a distanza un segnale elettrico. A seconda dei tipi, devono essere applicati sul coperchio del serbatoio con giacitura verticale in modo che il galleggiante disti almeno 50 mm. dalle pareti metalliche.

DATI TECNICI COMUNI

Lunghezza asta max	A = 1500 mm
Campo di temperatura	-20 ÷ +40°C
Peso specifico liquido	≥ 0,8
Pressione massima	10 Bar
Viscosità del fluido	max 150 cSt

DATI TECNICI LM1 - LMM1

Potenza commutabile in CC/CA	60 W/VA
Intensità di corrente	0,8 A (resistivi)
Tensione di lavoro	220 V - 50 Hz
Tensione di breakdown	300 V
Capacità dei contatti aperti	0,6 pF
Resistenza d'isolamento	10 ¹⁰ Ohm
Contatto a riposo (senza fluido)	NC (NA su richiesta)
Livello min. (LM1-LMM1)	NC (NA su richiesta)
Livello max (LMM1)	NC (NA su richiesta)

DATI TECNICI LM2

Potenza commutabile in CC/CA	30 W/VA
Intensità di corrente	0,5 A (resistivi)
Tensione di lavoro	220 V - 50 Hz
Tensione di breakdown	300 V
Capacità dei contatti aperti	2 pF
Resistenza d'isolamento	10 ⁹ Ohm

MATERIAL: G1 1/4" threaded flange in stainless steel; stainless steel tube; stop rings in stainless steel; stainless steel float, varnished die-cast aluminium housing.

N.B. - On customer's request we supply superior or different lengths from those indicated in reference table.

USE

This series of electromagnetic level indicators has been designed to check a fluid level in a tank and send an electric signal to a remote board. These level indicators must be set vertically on the cover of the tank, with the float at least 50 mm far from the metal walls.

STANDARD TECHNICAL DATA

Level max length	A = 1500 mm
Temperature range	-20 ÷ +40°C
Fluid specific weight	≥ 0,8
Maximum pressure	10 Bar
Fluid viscosity	max 150 cSt

LM1-LMM1 TECHNICAL DATA

Power commutated in DC/AC	60 W/VA
Intensity of current	0,8 A (resistive)
Voltage	220 V - 50 Hz
Breakdown voltage	300 V
Open contacts capacity	0,6 pF
Insulation resistance	10 ¹⁰ Ohm
Idle contact (without fluid)	NC (NO on request)
Min level (LM1-LMM1)	NC (NO on request)
Max level (LMM1)	NC (NO on request)

LM2 TECHNICAL DATA

Power commutated in DC/AC	30 W/VA
Intensity of current	0,5 A (resistive)
Voltage	220 V - 50 Hz
Breakdown voltage	300 V
Open contacts capacity	2 pF
Insulation resistance	10 ⁹ Ohm

LIVELLOSTATI ELETTROMAGNETICI - ESEC. ANTIDEFLAGRANTE

Electromagnetic level indicators - Explosion Proof execution

EExd II CT6 - EN 50014 - 18

Type LM1GTA... EP LM2GTA... EP

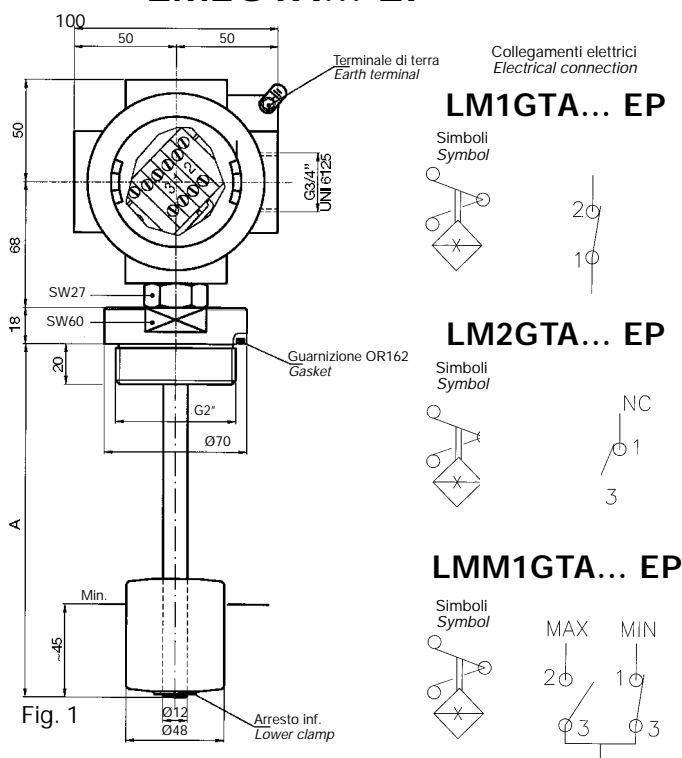

Type LMM1GTA... B... EP

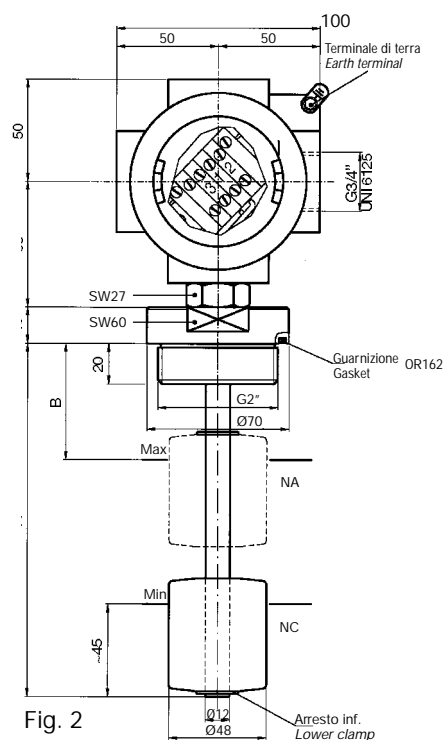

COSTRUZIONE: flangia filettata in ottone, tubo in ottone, anelli di arresto in bronzo, galleggianti in resina espansa NBR, custodia in alluminio pressofuso verniciato.

N.B. - A richiesta, forniamo lunghezza superiori, oppure diverse da quelle indicate in tabella.

IMPIEGO

Sono stati studiati per controllare il livello dell'olio, acqua, solventi, in un serbatoio e per inviare a distanza un segnale elettrico. A seconda dei tipi, devono essere applicati sul coperchio del serbatoio con giacitura verticale in modo che il galleggiante disti almeno 50 mm. dalle pareti metalliche.

DATI TECNICI COMUNI

Lunghezza asta max	A = 2500 mm
Campo di temperatura	-20 ÷ +40°C
Peso specifico liquido	≥ 0,8
Pressione massima	10 Bar
Viscosità del fluido	max 150 cSt

DATI TECNICI LM1 - LMM1

Potenza commutabile in CC/CA	60 W/VA
Intensità di corrente	0,8 A (resistivi)
Tensione di lavoro	220 V - 50 Hz
Tensione di breakdown	300 V
Capacità dei contatti aperti	0,6 pF
Resistenza d'isolamento	10 ¹⁰ Ohm
Contatto a riposo (senza fluido)	NC (NA su richiesta)
Livello min. (LM1-LMM1)	NC (NA su richiesta)
Livello max (LMM1)	NC (NA su richiesta)

DATI TECNICI LM2

Potenza commutabile in CC/CA	30 W/VA
Intensità di corrente	0,5 A (resistivi)
Tensione di lavoro	220 V - 50 Hz
Tensione di breakdown	300 V
Capacità dei contatti aperti	2 pF
Resistenza d'isolamento	10 ⁹ Ohm

MATERIAL: threaded flange in brass; brass tube; stop ring in bronze; NBR expended resin float, varnished die-cast aluminium housing.

N.B. - On customer's request we supply superior or different lengths from those indicated in the reference table.

USE

This series of electromagnetic level indicators has been designed to check a fluid level in a tank and send an electric signal to a remote board. These level indicators must be set vertically on the cover of the tank, with the float at least 50 mm far from metal walls.

STANDARD TECHNICAL DATA

Level max length	A = 1500 mm
Temperature range	-20 ÷ +40°C
Fluid specific weight	≥ 0,8
Maximum pressure	10 Bar
Fluid viscosity	max 150 cSt

LM1-LMM1 TECHNICAL DATA

Power commutated in DC/AC	60 W/VA
Intensity of current	0,8 A (resistive)
Voltage	220 V - 50 Hz
Breakdown voltage	300 V
Open contacts capacity	0,6 pF
Insulation resistance	10 ¹⁰ Ohm
Idle contact (without fluid)	NC (NO on request)
Min level (LM1-LMM1)	NC (NO on request)
Max level (LMM1)	NC (NO on request)

LM2 TECHNICAL DATA

Power commutated in DC/AC	30 W/VA
Intensity of current	0,5 A (resistive)
Voltage	220 V - 50 Hz
Breakdown voltage	300 V
Open contacts capacity	2 pF
Insulation resistance	10 ⁹ Ohm

LIVELLOSTATI ELETTROMAGNETICI - INOX - ESEC. ANTIDEFAGRANTE

Electromagnetic level indicators - Stainless steel - Explosion Proof execution

EExd II CT6 - EN 50014 - 18

Type LM1GTIA... EP LM2GTIA... EP

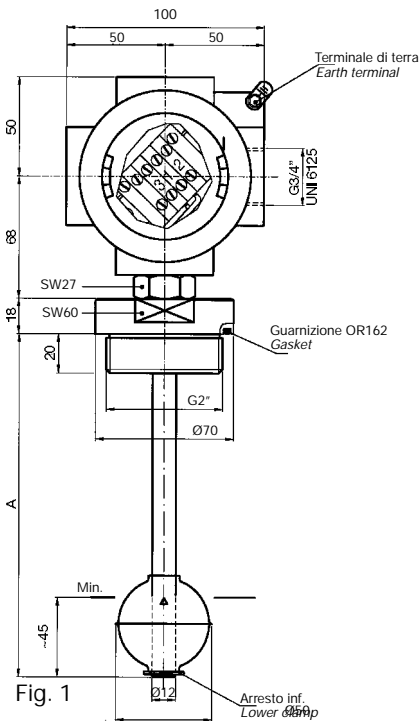

Collegamenti elettrici
Electrical connection

LM1GTIA... EP

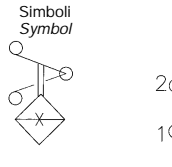

LM2GTIA... EP

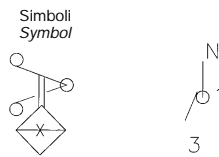

LMM1GTIA... EP

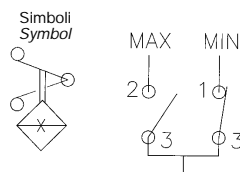

Type LMM1GTIA... EP

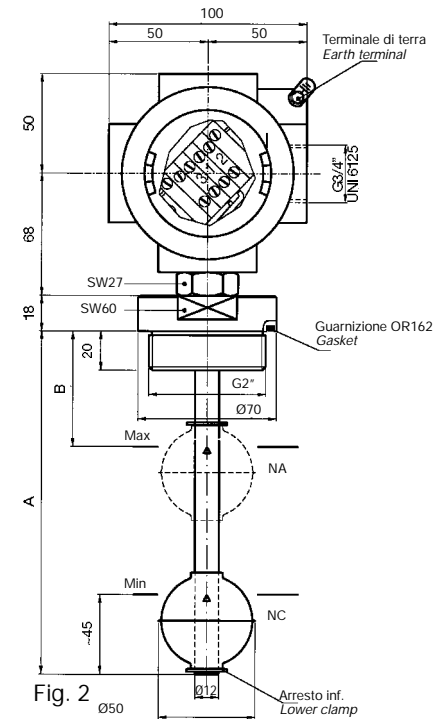

COSTRUZIONE: flangia filettata in acciaio inox, tubo in inox, ed anelli di arresto in inox, galleggianti in inox, custodia in alluminio pressofuso verniciato.

N.B. - A richiesta, forniamo lunghezza superiori, oppure diverse da quelle indicate in tabella.

IMPIEGO

Sono stati studiati per controllare il livello dell'olio, acqua, solventi, in un serbatoio e per inviare a distanza un segnale elettrico. A seconda dei tipi, devono essere applicati sul coperchio del serbatoio con giacitura verticale in modo che il galleggiante disti almeno 50 mm. dalle pareti metalliche.

DATI TECNICI COMUNI

Lunghezza asta max	A = 2500 mm
Campo di temperatura	-20 ÷ +40°C
Peso specifico liquido	≥ 0,8
Pressione massima	10 Bar
Viscosità del fluido	max 150 cSt

DATI TECNICI LM1 - LMM1

Potenza commutabile in CC/CA	60 W/VA
Intensità di corrente	0.8 A (resistivi)
Tensione di lavoro	220 V - 50 Hz
Tensione di breakdown	300 V
Capacità dei contatti aperti	0,6 pF
Resistenza d'isolamento	10 ¹⁰ Ohm
Contatto a riposo (senza fluido)	
Livello min. (LM1-LMM1)	NC (NA su richiesta)
Livello max (LMM1)	NC (NA su richiesta)

DATI TECNICI LM2

Potenza commutabile in CC/CA	30 W/VA
Intensità di corrente	0.5 A (resistivi)
Tensione di lavoro	220 V - 50 Hz
Tensione di breakdown	300 V
Capacità dei contatti aperti	2 pF
Resistenza d'isolamento	10 ⁹ Ohm

MATERIAL: threaded flange in stainless steel, tube in stainless steel, stop rings in stainless steel, float in stainless steel, varnished die-cast aluminium housing.

N.B. - On customer's request we supply superior or different lengths from those indicated in the reference table.

USE

This series of electromagnetic level indicators has been designed to check a fluid level in a tank and send an electric signal to a remote board. These level indicators must be set vertically on the cover of the tank, with the float at least 50 mm far from metal walls.

STANDARD TECHNICAL DATA

Level max length	A = 1500 mm
Temperature range	-20 ÷ +40°C
Fluid specific weight	≥ 0,8
Maximum pressure	10 Bar
Fluid viscosity	max 150 cSt

LM1-LMM1 TECHNICAL DATA

Power commutated in DC/AC	60 W/VA
Intensity of current	0.8 A (resistive)
Voltage	220 V - 50 Hz
Breakdown voltage	300 V
Open contacts capacity	0,6 pF
Insulation resistance	10 ¹⁰ Ohm
Idle contact (without fluid)	
Min level (LM1-LMM1)	NC (NO on request)
Max level (LMM1)	NC (NO on request)

LM2 TECHNICAL DATA

Power commutated in DC/AC	30 W/VA
Intensity of current	0.5 A (resistive)
Voltage	220 V - 50 Hz
Breakdown voltage	300 V
Open contacts capacity	2 pF
Insulation resistance	10 ⁹ Ohm

LIVELLOSTATI ELETTROMAGNETICI - ESEC. ANTIDEFLAGRANTE

Electromagnetic level indicators - Explosion Proof execution

EExd II CT6 - EN 50014 - 18

Type LM3 GTA... B... C... EP

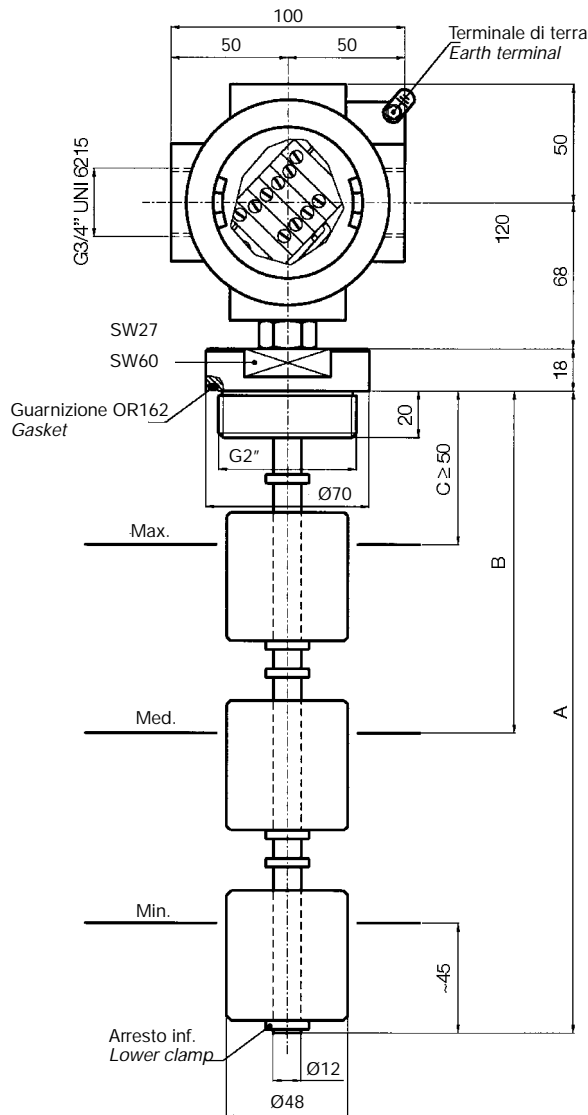

Type LM4 GTA... B... C... D... EP

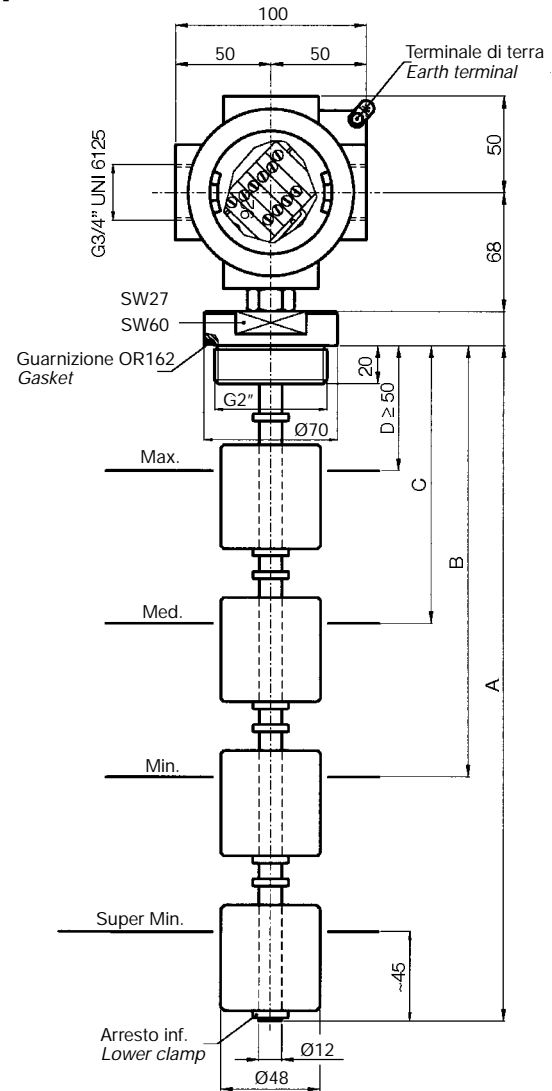

N.B. - Nelle ordinazioni indicare le quote A - B - C.
 A max = 2500 mm - Min. distanza fra i contatti B - C = 90 mm.
 Esempio di ordinazione: LM3GTA1200B500C100EP
 COSTRUZIONE: flangia filettata in ottone, tubo in ottone, anelli di arresto in ottone, galleggiante in resina espansa NBR.

IMPIEGO

Sono stati studiati per controllare il livello dell'olio, acqua, solventi, in un serbatoio e per inviare a distanza un segnale elettrico. A seconda dei tipi, devono essere applicati sul coperchio del serbatoio con giacitura verticale in modo che il galleggiante disti almeno 50 mm. dalle pareti metalliche.

DATI TECNICI

Lunghezza asta max	A = 2500 mm
Distanza min. fra B-C-D	90 mm
Potenza commutabile in CC	60 W
Potenza commutabile in CA	60 VA
Intensità di corrente	0,8 A (resistivi)
Tensione max. di lavoro	220 V - 50 Hz
Tensione di breakdown	300 V
Capacità dei contatti aperti	0,6 pF
Contatto a riposo (senza fluido)	NC (NA su richiesta)
Campo di temperatura	-20 ÷ 40°C
Resistenza d'isolamento	10 ¹⁰ OHM
Peso specifico liquido	≥ 0,7
Pressione massima	20 Bar
Viscosità del fluido	max 150 cSt

PER CARICHI INDUTTIVI IMPIEGARE CIRCUITO DI PROTEZIONE.

N.B. - In the order indicate the dimensions A - B - C - D.
 A max = 2500 mm - Min. contact distance B - C - D = 90 mm.
 Example of order: LM4GTA1500B1200C200D50EP
 MATERIAL: threaded flange in brass; brass tube; stop rings in brass; NBR expended resin float.

USE

This series of electromagnetic level indicators has been designed to check a fluid level in a tank and send an electric signal to a remote board. These level indicators must be set vertically on the cover of the tank, with the float at least 50 mm from metal walls.

TECHNICAL DATA

Level max length	A = 2500 mm
Distance min. B-C-D	90 mm
Power commutated in DC	60 W
Power commutated in AC	60 VA
Intensity of current	0,8 A (resistive)
Voltage	220 V - 50 Hz
Breakdown voltage	300 V
Open contacts capacity	0,6 pF
Idle contact (without fluid)	NC (NO on request)
Temperature range	-20 ÷ 40°C
Insulation resistance	10 ¹⁰ OHM
Fluid specific weight	≥ 0,7
Maximum pressure	20 Bar
Fluid viscosity	max 150 cSt

WITH INDUCTIVE LOADS A PROTECTION CIRCUIT IS TO BE USED.

LIVELLOSTATI ELETTROMAGNETICI - INOX - ESEC. ANTIDEFAGRANTE

Electromagnetic level indicators - Stainless steel - Explosion Proof execution

EExd II CT6 - EN 50014 - 18

Type LM3 GTIA... B... C... EP

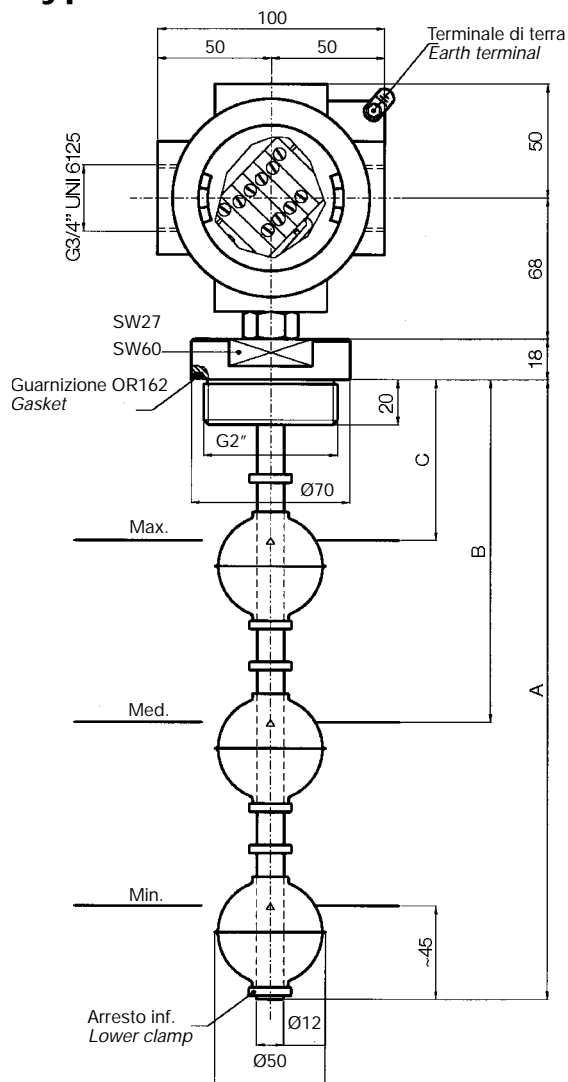

Type LM4 GTIA... B... C... D... EP

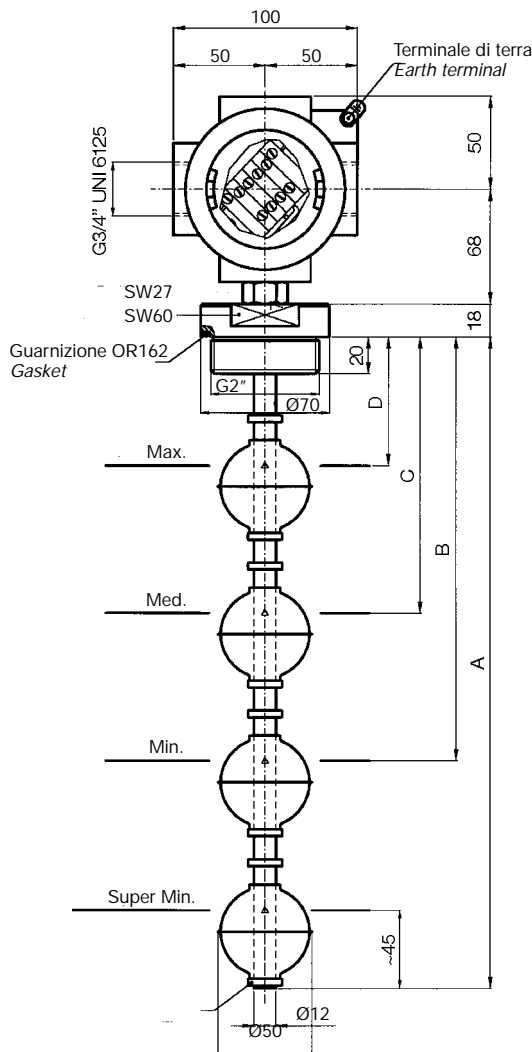

N.B. - Nelle ordinazioni indicare le quote A - B - C.
A max = 2500 mm - Min. distanza fra i contatti B - C = 90 mm.

Esempio di ordinazione: LM3GTIA1000B500C200EP

COSTRUZIONE: flangia filettata in acciaio inox, tubo in inox, ed anelli di arresto in inox, galleggiante in inox, custodia in alluminio pressofuso verniciato.

IMPIEGO

Sono stati studiati per controllare il livello dell'olio, acqua, solventi, in un serbatoio e per inviare a distanza un segnale elettrico. A seconda dei tipi, devono essere applicati sul coperchio del serbatoio con giacitura verticale in modo che il galleggiante disti almeno 50 mm. dalle pareti metalliche.

DATI TECNICI

Lunghezza asta max	A = 2500 mm
Distanza min. fra B-C-D	90 mm
Potenza commutabile in CC	60 W
Potenza commutabile in CA	60 VA
Intensità di corrente	0,8 A (resistivi)
Tensione max. di lavoro	220 V - 50 Hz
Tensione di breakdown	300 V
Capacità dei contatti aperti	0,6 pF
Contatto a riposo (senza fluido)	NC (NA su richiesta)
Campo di temperatura	-20 ÷ 40°C
Resistenza d'isolamento	10 ¹⁰ OHM
Peso specifico liquido	≥ 0,7
Pressione massima	20 Bar
Viscosità del fluido	max 150 cSt

PER CARICHI INDUTTIVI IMPIEGARE CIRCUITO DI PROTEZIONE.

N.B. - In the order indicate the dimensions A - B - C - D.
A max = 2500 mm - Min. contact distance B - C - D = 90 mm.

Example of order: LM4GTIA1500B1200C200D50EP

MATERIAL: threaded flange in stainless steel, tube in stainless steel, stop rings in stainless steel, float in stainless steel, varnished die-cast aluminium housing.

USE

This series of electromagnetic level indicators has been designed to check a fluid level in a tank and send an electric signal to a remote board. These level indicators must be set vertically on the cover of the tank, with the float at least 50 mm far from metal walls.

TECHNICAL DATA

Level max length	A = 2500 mm
Distance min. B-C-D	90 mm
Power commutated in DC	60 W
Power commutated in AC	60 VA
Intensity of current	0,8 A (resistive)
Voltage	220 V - 50 Hz
Breakdown voltage	300 V
Open contacts capacity	0,6 pF
Idle contact (without fluid)	NC (NO on request)
Temperature range	-20 ÷ 40°C
Insulation resistance	10 ¹⁰ OHM
Fluid specific weight	≥ 0,7
Maximum pressure	20 Bar
Fluid viscosity	max 150 cSt

WITH INDUCTIVE LOADS A PROTECTION CIRCUIT IS TO BE USED.

LIVELLOSTATI ELETTROMAGNETICI - IN PVC

Electromagnetic level indicators - PVC

Type LM... GSP... LMM1GSP

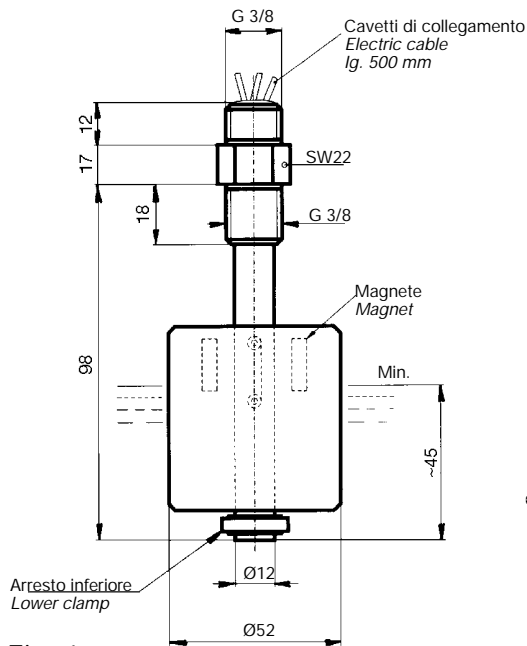
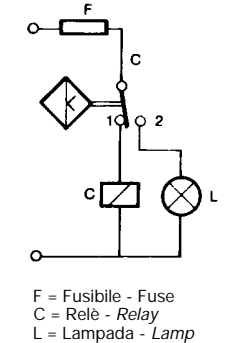

Fig. 1

Schema di applicazione
Application chart



Riempimento automatico
Automatic filling

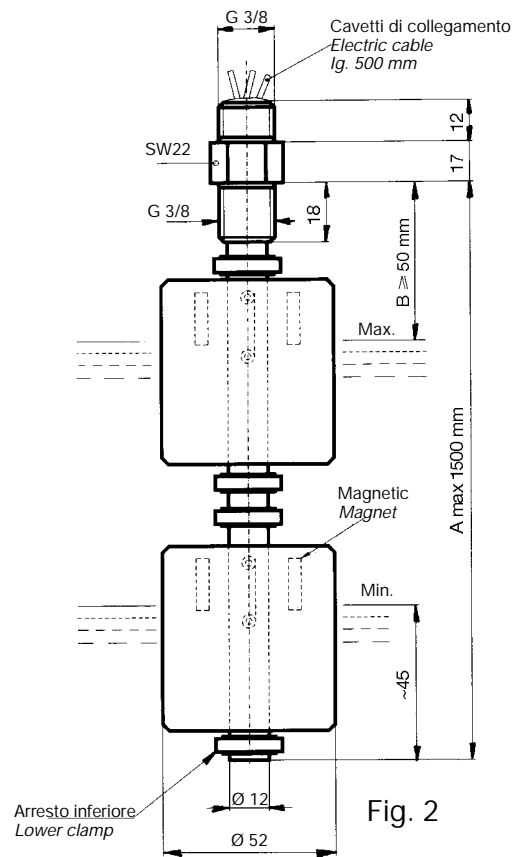
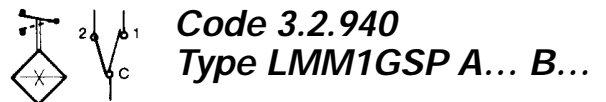

Fig. 2



N.B. - Nelle ordinazioni indicare le quote A e B.
N.B. - In the order indicate the dimensions A and B

IMPIEGO

Questi livellostati sono stati studiati per controllare il minimo o il massimo livello di un fluido contenuto in un serbatoio e per inviare un segnale elettrico di allarme a distanza. A seconda dei tipi devono essere applicati sul coperchio del serbatoio con giacitura verticale in modo che il galleggiante disti almeno 50 mm. dalle pareti metalliche ferrose.

DATI TECNICI COMUNI

Campo di temperatura	-5° ÷ +50°C
Peso specifico liquido	≥ 0,8
Pressione massima	5 Bar
Viscosità del fluido	max 150 cSt

DATI TECNICI LM1 - LMM1

Potenza commutabile in CC/CA	60 W/VA
Intensità di corrente	0,8 A (resistivi)
Tensione di lavoro	220 V - 50 Hz
Tensione di breakdown	300 V
Capacità dei contatti aperti	0,6 pF
Resistenza d'isolamento	10 ¹⁰ Ohm
Contatto a riposo (senza fluido)	
Livello min. (LM1 - LMM1)	NC (NA su richiesta)
Livello max (LMM1)	NC (NA su richiesta)

DATI TECNICI LM2

Potenza commutabile in CC/CA	30 W/VA
Intensità di corrente	0,5 A (resistivi)
Tensione di lavoro	220 V - 50 Hz
Tensione di breakdown	300 V
Capacità dei contatti aperti	2 pF
Resistenza d'isolamento	10 ⁹ Ohm

USE

This series of electromagnetic level indicators has been designed to check the minimum or maximum level of a fluid in a tank and send an electric signal to a remote board in case the fluid goes over or under the set levels. These level indicators should be fixed vertically on the cover of the tank, with the float at least 50 mm far from metal walls.

STANDARD TECHNICAL DATA

Temperature range	-5° ÷ +50°C
Fluid specific weight	≥ 0,8
Maximum pressure	5 Bar
Fluid viscosity	max 150 cSt

LM1-LMM1 TECHNICAL DATA

Power commutated in DC/AC	60 W/VA
Intensity of current	0,8 A (resistive)
Voltage	220 V - 50 Hz
Breakdown voltage	300 V
Open contacts capacity	0,6 pF
Insulation resistance	10 ¹⁰ Ohm
Idle contact (without fluid)	
Min level (LM1-LMM1)	NC (NO on request)
Max level (LMM1)	NC (NO on request)

LM2 TECHNICAL DATA

Power commutated in DC/AC	30 W/VA
Intensity of current	0,5 A (resistive)
Voltage	220 V - 50 Hz
Breakdown voltage	300 V
Open contacts capacity	2 pF
Insulation resistance	10 ⁹ Ohm

LIVELLOSTATI ELETTROMAGNETICI - IN PVC

Electromagnetic level indicators - PVC

Type LM3 GSPA... B... C...

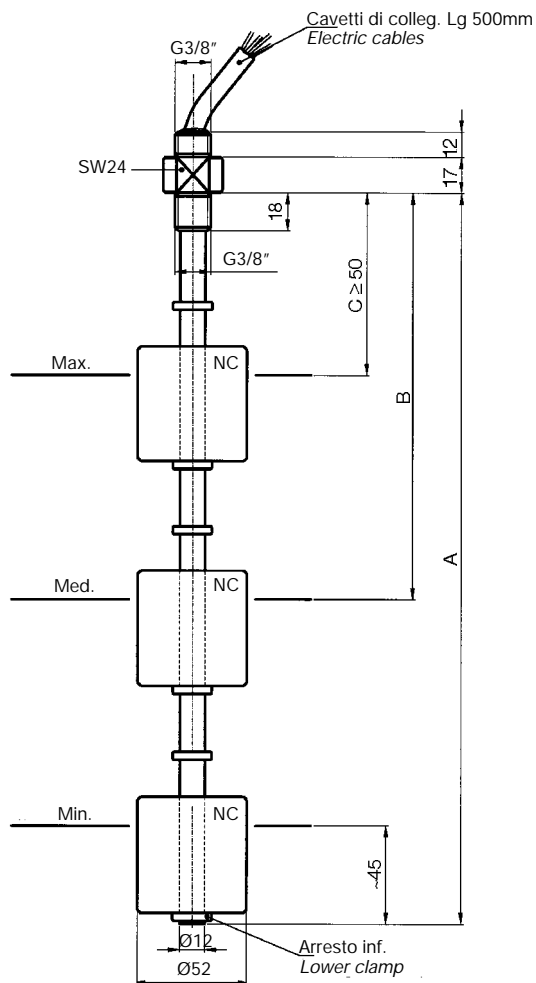

Type LM4 GSPA... B... C... D...

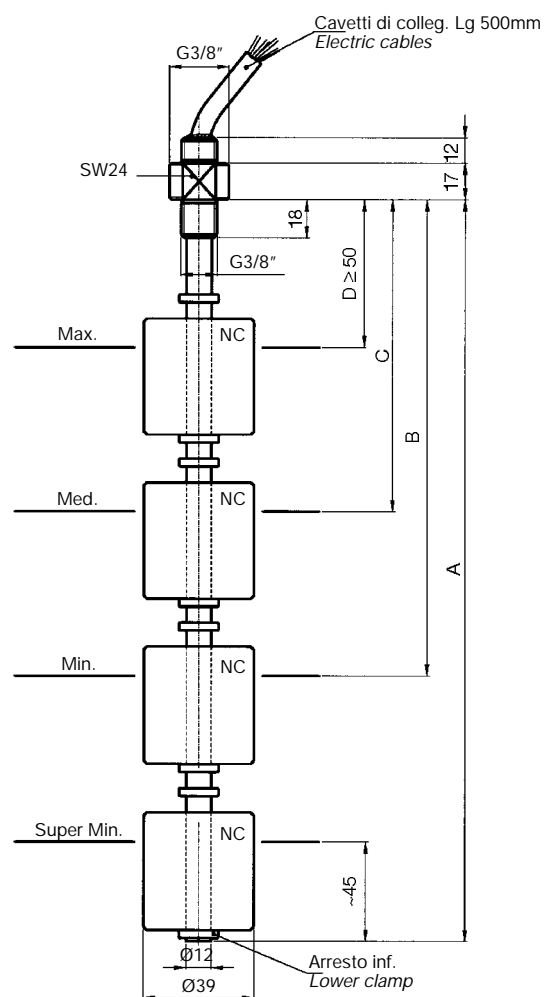

N.B. - Nelle ordinazioni indicare le quote B - C.
A max = 2500 mm - Min. distanza fra i contatti B - C = 90 mm.

Esempio di ordinazione: LM3GSPA1000B800C50

IMPIEGO

Sono stati studiati per controllare il minimo o il massimo livello dell'olio, acqua, solventi, in un serbatoio e per inviare a distanza un segnale elettrico. A seconda dei tipi, devono essere applicati sul coperchio del serbatoio con giacitura verticale in modo che il galleggiante disti almeno 50 mm. dalle pareti metalliche ferrose.

DATI TECNICI

Potenza commutabile in CC	60 W
Potenza commutabile in CA	60 VA
Intensità di corrente	0,8 A (resistivi)
Tensione max. di lavoro	~220 V - 50 Hz
Tensione di breakdown	300 V
Capacità dei contatti aperti	0,6 pF
Contatto a riposo (senza fluido)	NC (NA su richiesta)
Campo di temperatura	-5 +50°C
Resistenza d'isolamento	10 ¹⁰ OHM
Peso specifico liquido	≥ 0,85
Pressione massima	5 Bar
Viscosità del fluido	150 cSt
Costruzione	tubo galleggiante in PVC

PER CARICHI INDUTTIVI IMPIEGARE CIRCUITO DI PROTEZIONE.

N.B. - In the order indicate the dimensions A - B - C - D.
A max = 2500 mm - Min. contact distance B - C - D = 90 mm.

Example of order: LM4GSPA100B800C150D50

USE

This series of electromagnetic level indicators has been designed to check the minimum or maximum level of a fluid in a tank and send an electric signal to a remote board in case the fluid goes over or under the set levels. These level indicators should be fixed vertically on the cover of the tank, with the float at least 50 mm far from metal walls.

TECHNICAL DATA

Power commutated in DC	60 W
Power commutated in AC	60 VA
Intensity of current	0,8 A (resistive)
Voltage	~220 V - 50 Hz
Breakdown voltage	300 V
Open contacts capacity	0,6 pF
Idle contact (without fluid)	NC (NO on request)
Temperature range	-5 +50°C
Insulation resistance	10 ¹⁰ OHM
Fluid specific weight	≥ 0,85
Maximum pressure	5 Bar
Fluid viscosity	max 150 cSt
Material	tube, float in PVC

WITH INDUCTIVE LOADS A PROTECTION CIRCUIT IS TO BE USED.

LIVELLOSTATI ELETTROMAGNETICI - IN PVC

Electromagnetic level indicators - PVC

Type **LM1GPA...**
LM2GPA...

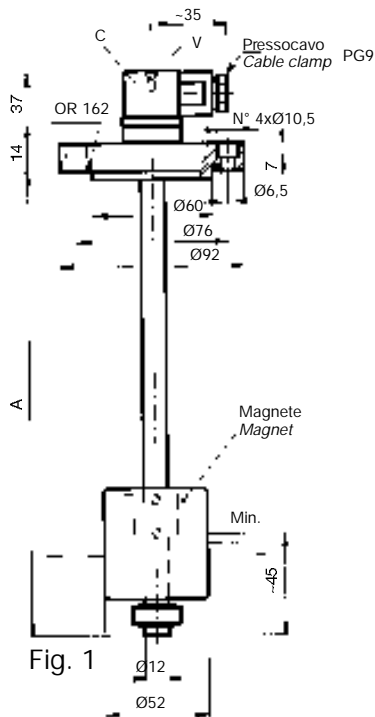

Collegamenti elettrici
Electrical connection

LM1GPA...

Simboli
Symbol

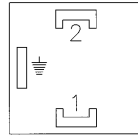
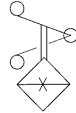

LM2GPA...

Simboli
Symbol

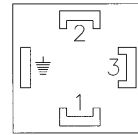
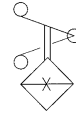

LMM1GPA...

Simboli
Symbol

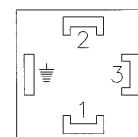
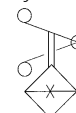

Type **LMM1GPA...**

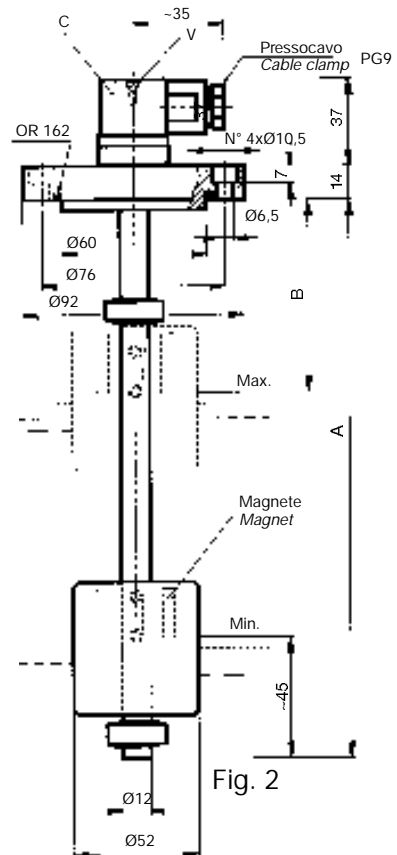

COSTRUZIONE: flangia, tubo, anelli d'arresto e galleggiante in PVC.

MATERIAL: flange, tube, stop ring and float in PVC.

N.B. - A richiesta, forniamo lunghezze superiori, oppure diverse da quelle indicate in tabella.

N.B. - On customer's request we supply superior or different lengths from those indicated in the reference table.

IMPIEGO

Sono stati studiati per controllare il vello dell'olio, acqua, solventi, in un serbatoio e per inviare a distanza un segnale elettrico. A seconda dei tipi, devono essere applicati sul coperchio del serbatoio con giacitura verticale in modo che il galleggiante disti almeno 50 mm. dalle pareti metalliche.

USE

This series of electromagnetic level indicators has been designed to check the minimum or maximum level of a fluid in a tank and send an electric signal to a remote board in case the fluid goes over or under the set levels. These level indicators should be fixed vertically on the cover of the tank, with the float at least 50 mm far from metal walls.

DATI TECNICI COMUNI

Lunghezza asta max A = 2500 mm
 Campo di temperatura -5° ÷ +50°C
 Peso specifico liquido ≥ 0,8
 Pressione massima 5 Bar
 Viscosità del fluido max 150 cSt

STANDARD TECHNICAL DATA

Level max length A = 1500 mm
 Temperature range -5° ÷ +50°C
 Fluid specific weight ≥ 0,8
 Maximum pressure 10 Bar
 Fluid viscosity max 150 cSt

DATI TECNICI LM1 - LMM1

Potenza commutabile in CC/CA 60 W/VA
 Intensità di corrente 0,8 A (resistivi)
 Tensione di lavoro 220 V - 50 Hz
 Tensione di breakdown 300 V
 Capacità dei contatti aperti 0,6 pF
 Resistenza d'isolamento 10¹⁰ Ohm
 Contatto a riposo (senza fluido) NC (NA su richiesta)
 Livello min. (LM1-LMM1) NC (NA su richiesta)
 Livello max (LMM1) NC (NA su richiesta)

LM1-LMM1 TECHNICAL DATA

Power commutated in DC/AC 60 W/VA
 Intensity of current 0,8 A (resistive)
 Voltage 220 V - 50 Hz
 Breakdown voltage 300 V
 Open contacts capacity 0,6 pF
 Insulation resistance 10¹⁰ Ohm
 Idle contact (without fluid) NC (NO on request)
 Min level (LM1-LMM1) NC (NO on request)
 Max level (LMM1) NC (NO on request)

DATI TECNICI LM2

Potenza commutabile in CC/CA 30 W/VA
 Intensità di corrente 0,5 A (resistivi)
 Tensione di lavoro 220 V - 50 Hz
 Tensione di breakdown 300 V
 Capacità dei contatti aperti 2 pF
 Resistenza d'isolamento 10¹⁰ Ohm

LM2 TECHNICAL DATA

Power commutated in DC/AC 30 W/VA
 Intensity of current 0,5 A (resistive)
 Voltage 220 V - 50 Hz
 Breakdown voltage 300 V
 Open contacts capacity 2 pF
 Insulation resistance 10¹⁰ Ohm

LIVELLOSTATI ELETTROMAGNETICI - IN PVC

Electromagnetic level indicators - PVC

Type LM4GPA... B... C... D...

Type LM3GPA... B... C...

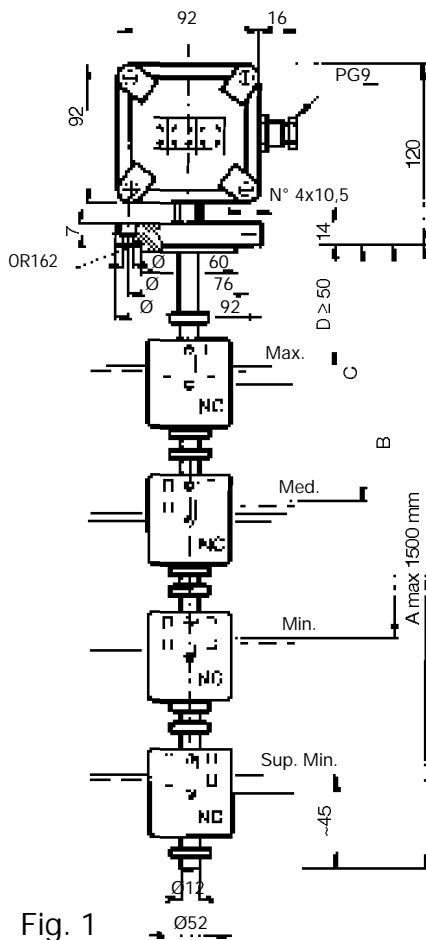

Fig. 1

A MAX ... 2500 mm.
B-C-D MIN ... 90 mm.

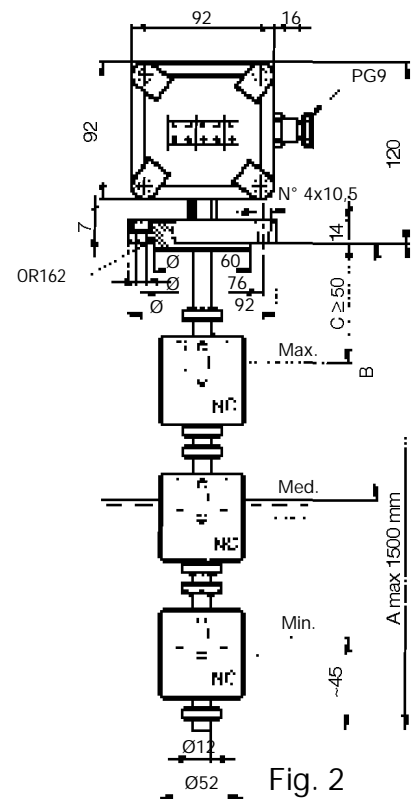

Fig. 2

N.B. - Nelle ordinazioni indicare le quote A - B - C - D.
A max = 2500 mm - Min. distanza fra i contatti B - C - D = 90 mm.

Esempio di ordinazione: LM4GPA1500B1200C200D50

IMPIEGO

Sono stati studiati per controllare livello dell'olio, acqua, solventi, in un serbatoio e per inviare a distanza un segnale elettrico. A seconda dei tipi, devono essere applicati sul coperchio del serbatoio con giacitura verticale in modo che il galleggiante disti almeno 50 mm. dalle pareti metalliche ferrose.

DATI TECNICI

Potenza commutabile in CC	60 W
Potenza commutabile in CA	60 VA
Intensità di corrente	0.8 A (resistivi)
Tensione max. di lavoro	~220 V - 50 Hz
Tensione di breakdown	300 V
Capacità dei contatti aperti	0,6 pF
Contatto a riposo (senza fluido)	NC (NA su richiesta)
Campo di temperatura	-5 +50°C
Resistenza d'isolamento	10 ¹⁰ OHM
Peso specifico liquido	≥ 0,85
Pressione massima	5 Bar
Viscosità del fluido	150 cSt
Costruzione	flangia, tubo galleggiante in PVC

PER CARICHI INDUTTIVI IMPIEGARE CIRCUITO DI PROTEZIONE.

N.B. - In the order indicate the dimensions A - B - C - D.
A max = 2500 mm - Min. contact distance A - B - C - D = 90 mm.

Example of order: LM3GPA1500B1250C50

USE

This series of electromagnetic level indicators has been designed to check the level of a fluid in a tank and send an electric signal to a remote board in case the fluid goes over or under the set levels. These level indicators should be fixed vertically on the cover of the tank, with the float at least 50 mm far from metal walls.

TECHNICAL DATA

Power commutated in DC	60 W
Power commutated in AC	60 VA
Intensity of current	0.8 A (resistive)
Voltage	~220 V - 50 Hz
Breakdown voltage	300 V
Open contacts capacity	0,6 pF
Idle contact (without fluid)	NC (NO on request)
Temperature range	-5 +50°C
Insulation resistance	10 ¹⁰ OHM
Fluid specific weight	≥0.85
Maximum pressure	5 Bar
Fluid viscosity	max 150 cSt
Material	flange, tube, float in PVC

WITH INDUCTIVE LOADS A PROTECTION CIRCUIT IS TO BE USED.

LIVELLOSTATI ELETTROMAGNETICI - IN PVC

Electromagnetic level indicators - PVC

Type LM4GTPA... B... C... D...

Type LM3GTPA... B... C...

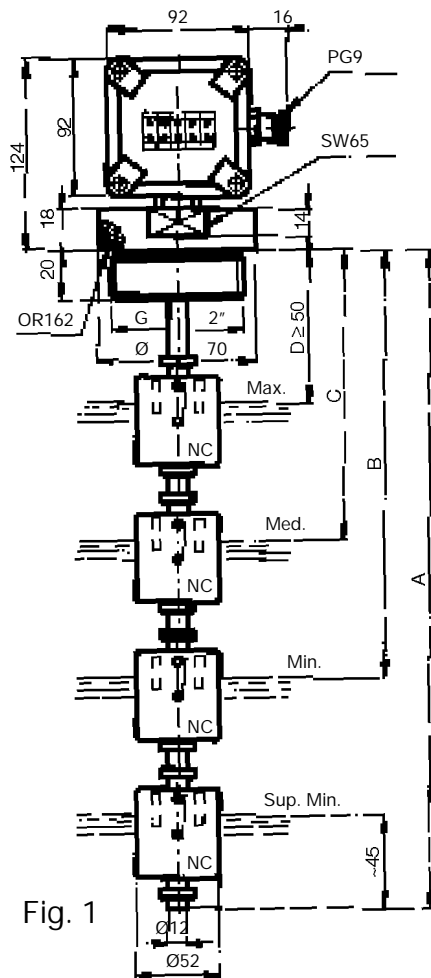

A MAX ... 2500 mm.
B-C-D MIN ... 90 mm.

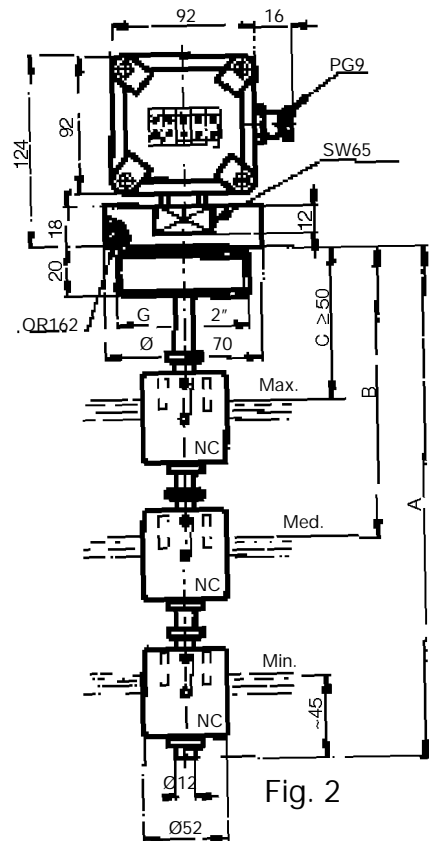

Fig. 2

N.B. - Nelle ordinazioni indicare le quote A - B - C - D.
A max = 2500 mm - Min. distanza fra i contatti B - C - D = 90 mm.

Esempio di ordinazione: LM4GTPA1500B1200C200D50

IMPIEGO

Sono stati studiati per controllare il livello dell'olio, acqua, solventi, in un serbatoio e per inviare a distanza un segnale elettrico. A seconda dei tipi, devono essere applicati sul coperchio del serbatoio con giacitura verticale in modo che il galleggiante disti almeno 50 mm. dalle pareti metalliche ferrose.

DATI TECNICI

Potenza commutabile in CC	60 W
Potenza commutabile in CA	60 VA
Intensità di corrente	0.8 A (resistivi)
Tensione max. di lavoro	~220 V - 50 Hz
Tensione di breakdown	300 V
Capacità dei contatti aperti	0,6 pF
Contatto a riposo (senza fluido)	NC (NA su richiesta)
Campo di temperatura	-5 +50°C
Resistenza d'isolamento	10 ¹⁰ OHM
Peso specifico liquido	≥ 0,85
Pressione massima	5 Bar
Viscosità del fluido	150 cSt
Costruzione	flangia, tubo galleggiante in PVC

PER CARICHI INDUTTIVI IMPIEGARE CIRCUITO DI PROTEZIONE.

N.B. - In the order indicate the dimensions A - B - C.
A max = 2500 mm - Min. contact distance B - C = 90 mm.

Example contacts: LM3GTPA1000B800C50

USE

This series of electromagnetic level indicators has been designed to check the level of a fluid in a tank and send an electric signal to a remote board in case the fluid goes over or under the set levels. These level indicators should be fixed vertically on the cover of the tank, with the float at least 50 mm far from metal walls.

TECHNICAL DATA

Power commutated in DC	60 W
Power commutated in AC	60 VA
Intensity of current	0.8 A (resistive)
Voltage	~220 V - 50 Hz
Breakdown voltage	300 V
Open contacts capacity	0,6 pF
Idle contact (without fluid)	NC (NO on request)
Temperature range	-5 +50°C
Insulation resistance	10 ¹⁰ OHM
Fluid specific weight	≥ 0.85
Maximum pressure	5 Bar
Fluid viscosity	max 150 cSt
Material	flange, tube, float in PVC

WITH INDUCTIVE LOADS A PROTECTION CIRCUIT IS TO BE USED.

Company _____

Please refer to our Mr.

Field _____

_____ for next contact.

Address _____

Zip code _____ Town _____

State _____

Phone _____ Fax _____

e-mail _____

www _____

Name and surname _____

Job function _____

To



Via Jean Jaurés, 12 - 20125 MILANO (Italy)

Fax +39 0228851854

e-mail: vendite1@elettrotec.it

www.elettrotec.com

Inquiry

Type	Product Description	Quantity	Delivery Time
------	---------------------	----------	---------------

_____ operator

_____ signature

APPARECCHI DI CONTROLLO PER FLUIDI

Control Devices for Fluids

- Flussimetri
- Flussostati
- Livellostati
- Pressostati
- Vuotostati
- Termostati
- Sonde di livello continue
- Indicatori digitali
- Trasmettitori di pressione e pressostati elettronici
- Cappucci di protezione
- Connettori
- Flow indicators
- Flow switches
- Float level switches
- Pressure switches
- Vacuum switches
- Temperature switches
- Level sensors
- Programmable digital indicators
- Electronic pressure transmitters and switches
- Protection caps
- Connectors

ELETTROTEC srl si riserva la facoltà di apportare modifiche al presente catalogo in qualsiasi momento.
È vietata la riproduzione anche parziale.

*Specification are subject to change without any obligation of the part of ELETTROTEC srl.
No part of this publication may be reproduced, stored in a retrieval system, or transmitted in any form or
by any means without prior permission of ELETTROTEC srl.*

